

An aerial, grayscale photograph of a city street scene. The street is wide and runs vertically through the center. On the right side, there is a large, classical-style building with a prominent dome. The background shows a dense urban skyline with various skyscrapers. The overall tone is professional and formal.

Upper Extremity Maximum Medical Improvement and Impairment Rating

TDI Division of Workers'
Compensation

Video Disclaimer

The videos presented in this training are made available by the Texas Department of Insurance/Division of Workers' Compensation (TDI-DWC) for educational purposes only. The videos are not intended to represent the sole method or procedure appropriate for the medical situation discussed.

Material Disclaimer

The material presented in this presentation is made available by the Texas Department of Insurance/Division of Workers' Compensation (TDI-DWC) for educational purposes only. The material is not intended to represent the sole method, approach, procedure or opinion appropriate for the medical situations discussed.

When there is a conflict between DWC Statutes/Rules and The *AMA Guides*

**Be aware of when DWC Statutes
and Rules take precedence**



Case Based Assessment of:

**MAXIMUM
MEDICAL
IMPROVEMENT
(MMI)**

**IMPAIRMENT
RATING (IR)**

DESIGNATED DOCTOR CONCEPTS - MAXIMUM MEDICAL IMPROVEMENT (MMI)

Labor Code definition:

"The earliest date after which, based on reasonable medical probability, further material recovery from or lasting improvement to an injury can no longer reasonably be anticipated."

DESIGNATED DOCTOR CONCEPTS - MMI

MMI is established by:

- Applying the compensable diagnoses as established by the DD from the records and certifying exam,
- to the recommendations in the ODG and other evidence-based medicine with case specific details
- AND considering the definition of MMI

DESIGNATED DOCTOR CONCEPTS - MMI

130.1 (b) (4):

To Certify MMI the certifying doctor shall

- A. Review medical records;
- B. Perform a complete medical examination of the injured employee for the explicit purpose of determining MMI (certifying examination).

DESIGNATED DOCTOR CONCEPTS – MMI

Rule 130.1 (c) (3):

Assignment of impairment rating for the current compensable injury shall be based on the injured employee's condition on the MMI date considering the medical record and the certifying examination.

DESIGNATED DOCTOR CONCEPTS - IMPAIRMENT

As per page 1 of the AMA Guides,
"An impairment is a deviation from normal in a body part or organ system and its function".

DESIGNATED DOCTOR CONCEPTS - IMPAIRMENT

As per page 2 of the AMA Guides, 4th Edition

"Normal is not an absolute"

"An interpretation of normal that is too strict can result in an overestimation or underestimation of impairment."

- Certain values may be normal for a given person based on age, gender and other factors, and the contralateral extremity.

DESIGNATED DOCTOR CONCEPTS - IMPAIRMENT

AMA Guides, 4th Edition

- Other important pages in the AMA Guides instruct you as to how to approach a specific claim.
- Please review
 - Chapter 2, Section 2.2 on page 8 and 9
 - Chapter 3, page 14

DESIGNATED DOCTOR CONCEPTS - IMPAIRMENT

AMA Guides, 4th Edition – Chapter 2, Section 2.2 on page 8

- *“Tests of consistency, such as the one described to check the patient's lumbosacral spine range of motion (Chapter 3, Section 3.3j p. 113), are good but imperfect indicators of patients' efforts. The physician must utilize the entire gamut of clinical skill and judgment in assessing whether or not the results of measurements or tests are plausible and relate to the impairment being evaluated”.*
- *“If in spite of an observation or test result the medical evidence appears not to be of sufficient weight to verify that an impairment of a certain magnitude exists”.*

DESIGNATED DOCTOR CONCEPTS - IMPAIRMENT

AMA Guides, 4th Edition - Chapter 2, Section 2.2 on page 9

- *“Unless generally accepted standards exist, as with many laboratory tests, two measurements made by the same examiner and involving a patient or a patient's functions may be expected to lie within 10% of each other”.*
- *“Measurements should be consistent between two trained observers; if they have been made by one observer on separate occasions, they also should be consistent. Repeating measurements may increase their credibility”.*

DESIGNATED DOCTOR CONCEPTS - IMPAIRMENT

AMA Guides, 4th Edition - Chapter 3, page 14

- *“The tables of Chapter 3 are based on the **active** range of motion, which is determined with the patient's full effort and cooperation.*
- *“Comparing the patient's active range of motion with the passive range of motion provides useful information”.*
- *“Evaluating the range of motion of an extremity or of the spine is a valid method of estimating an impairment. To some extent, however, the range of motion is subject to the patient's control. The results of such evaluations should be consistent and concordant with the presence or absence of pathologic signs and other medical evidence”.*

Case 1 – Upper Extremity MMI/IR

History of Injury

- 25-year-old male working as painter lifted five-gallon bucket partially full of paint
- Heard pop and experienced immediate right shoulder pain

Case 1 - Upper Extremity MMI/IR

- Saw PCP date of injury and diagnosed with shoulder strain
- Treated with ibuprofen and PT
- Initial 6 visits of PT over 3 weeks
 - Codman's and other passive ROM
 - Scapular stabilization/control exercises
 - Rotator cuff resistance exercises with minimal shoulder abduction

Case 1 - Upper Extremity MMI/IR

- PCP follow-up **3 weeks post injury**
 - “Not better”
 - Restricted painful shoulder ROM
 - Shoulder flexion and abduction approximately 80°, IR/extension thumb to L5
 - RTW with restrictions – restricted duty work unavailable
- Orthopedic surgeon referral

Case 1 - Upper Extremity MMI/IR

- Orthopedic surgeon **5 weeks post injury**
 - Active shoulder abduction and flexion approximately 90 degrees
 - Inability to actively resist abduction (4/5)
 - Positive impingement signs
 - X-rays negative for fracture, dislocation, but Type III acromion
 - Ordered shoulder MR arthrogram right shoulder

Case 1 - Upper Extremity MMI/IR

- MR arthrogram **6 weeks post injury**
 - Partial thickness rotator cuff (supraspinatus) tear
 - Type III acromion
 - Subacromial effusion

Case 1 - Upper Extremity MMI/IR

- Orthopedic surgeon **7 weeks post injury**
 - Symptoms, activity tolerance and PE unchanged
 - Restricted duty work unavailable
 - Inability to actively resist abduction (4/5)
 - Subacromial corticosteroid and concurrent PT

Case 1 - Upper Extremity MMI/IR

- **PT 8-11 weeks post injury**
 - 6 additional visits
 - Concurrent with 2 subacromial corticosteroid injections
 - Progression of scapular and rotator cuff strengthening
 - Shoulder flexion 120°, extension 30°, adduction 30°, abduction 100°, IR 20°, ER 30° at discharge (12th visit of PT)
 - Restricted duty work still unavailable

Case 1 - Upper Extremity MMI/IR

- Orthopedic surgeon **12 weeks post injury**
 - Symptoms, activity tolerance improved
 - Shoulder abduction and flexion approximately 120°
 - Mildly positive impingement signs
 - Restricted duty work unavailable
 - Recommended continued 6 visits of PT
 - PT preauthorization denied, appealed
 - Insurance carrier "accepts shoulder sprain, denies partial thickness rotator cuff tear"

Case 1 - Upper Extremity MMI/IR

DD Exam - 20 Weeks Post Injury

- Medical History
 - States cannot use right arm well at all, especially above shoulder level
 - Right arm "really weak"
 - Right shoulder "stiff"
 - PT and injections helped, but no PT in about 8 weeks
 - Doing some exercises at home
 - Wants to work "but my boss won't let me"



Case 1 - Upper Extremity MMI/IR

DD Physical Exam - 20 Weeks Post Injury

- Shoulder flexion 110°, extension 30°, abduction 90°, adduction 20°, external rotation 20°, Internal rotation 10°
- 4/5 strength right shoulder abduction, flexion and external rotation when performed at > 45°- 60° of abduction or flexion
- UE DTRs and sensation normal

Case 1 – Upper Extremity MMI/IR

Based on medical records and physical exam, what is the compensable injury for certifying MMI and IR?

130.1(c)(3)



Case 1 – Upper Extremity MMI/IR

What is compensable injury
for certifying MMI and IR?

- A. Right shoulder strain
- B. Partial thickness right rotator cuff (supraspinatus) tear complicated by pre-existing Type III acromion
- C. A and B
- D. None of above



Case 1 – Upper Extremity MMI/IR

Question for DD to consider
in the exam:

Has MMI been reached?
If so, on what date?

*May not be greater than statutory
MMI date shown on DWC Form-032)*



Case 1 – Upper Extremity MMI/IR

Has MMI been reached?

If so, on what date?

- A. Yes, 11 weeks post injury,
date of 12th PT visit
- B. Yes, 12 weeks post injury,
date of ortho follow-up
- C. Yes, 20 weeks post injury,
date of DD exam
- D. No, not at MMI



Case 1 - Upper Extremity MMI/IR

Additional PT?

- ODG recommendations:
 - **Rotator Cuff syndrome / Impingement syndrome:**
 - Medical treatment: 10 visits over 8 weeks
 - Post-injection treatment: 1-2 visits over 1 week
 - **Sprained shoulder; rotator cuff tear:**
 - Medical treatment, sprain: 10 visits over 8 weeks
 - Medical treatment, tear: 20 visits over 10 weeks

Case 1 - Upper Extremity MMI/IR

Continued...

Appendix D

- Evidence of consistent functional improvement with treatment?
- Comorbidities / extenuating conditions or circumstances

Pre-authorization denial

- Relevance to DD's opinion?

Surgery?

Case 1 - Upper Extremity MMI/IR

- **Surgery for rotator cuff injury may be indicated for 1 or more of the following:**
 - Acute partial-thickness injury, chronic partial-thickness injury, or chronic full-thickness injury, as indicated by ALL of the following:
 - Disabling pain associated with rotator cuff injury
 - Full-thickness (complete) or partial-thickness (incomplete) tear documented on imaging studies (eg, magnetic resonance imaging [MRI]) that correlates with symptoms and exam findings

Case 1 - Upper Extremity MMI/IR

Continued...

- Lack of improvement with conservative therapy for at least 3 months (i.e., activity modification, nonsteroidal anti-inflammatory drug use, physical therapy)
- Other potential contributors to condition have been excluded (e.g., brachial plexus disorders, cervical pathology, fracture, thoracic outlet syndrome)

Case 1 - Upper Extremity MMI/IR

Continued...

- Acute traumatic full-thickness injury, as indicated by ALL of the following:
 - Disabling pain associated with rotator cuff injury
 - Full-thickness (complete) tear documented on imaging studies (i.e., MRI) that correlates with symptoms and physical examination findings
 - Injury results in functional deficit in affected arm (e.g., unable to elevate arm or externally rotate arm against resistance).
 - Secondary to acute trauma

Questions About Case 1 – UE MMI/IR?



**Case 1 –
Upper Extremity
MMI/IR**

The Sequel

DD Exam - 52 Weeks Post Injury

- Medical History
 - Arthroscopic rotator cuff repair with acromioplasty at 22 weeks post injury
 - Completed 24 visits weeks 34-48 post injury following post-op immobilization
 - RTW full time at new job 50 weeks post op with 50# lifting restriction no lifting > 25# above shoulder height

Case 1 - Upper Extremity MMI/IR

The Sequel

DD Exam - 52 Weeks Post Injury

- Medical History (cont'd)
 - PT discharge **48 weeks post injury**
 - 5/5 UE strength
 - Progression of resisted rotator cuff/scapular strengthening exercises
 - Shoulder ROM
 - flexion 160°
 - abduction 150°
 - adduction/IR thumb to T10

Case 1 - Upper Extremity MMI/IR

The Sequel

DD Exam - 52 Weeks Post Injury

- Medical History (cont'd)
 - Ortho follow up **49 weeks post injury**
 - "Much better, finished with PT, doing home exercises"
 - "Full ROM and strength"
 - Follow up prn



Case 1 - Upper Extremity MMI/IR

The Sequel

DD Physical Exam - 52 Weeks Post Injury

- Shoulder ROM
- Flexion 155°
- Extension 28°
- Abduction 150°
- Adduction 25°
- IR 40°
- ER 50°

Case 1 - Upper Extremity MMI/IR

The Sequel

DD Physical Exam - 52 Weeks Post Injury

- Intermittent AC joint crepitation with active right shoulder range of motion
- No significant scapulothoracic dyskinesia or crepitation
- 5/5 strength right shoulder with manual muscle testing
- Normal UE DTRs and sensation

Case 1 – Upper Extremity MMI/IR *The Sequel*

Based on medical records and physical exam, what is compensable injury for certifying MMI and IR?



Case 1 – Upper Extremity MMI/IR *The Sequel*

Question for DD to consider
in the exam:

Has MMI been reached?
If so, on what date?

*(May not be later than statutory MMI
date shown on DWC Form-032)*



Case 1 – Upper Extremity MMI/IR *The Sequel*

Has MMI been reached?
If so, on what date?

- A. Yes, 48 weeks post injury, date of PT discharge
- B. Yes, 49 weeks post injury, date of ortho follow-up
- C. Yes, 50 weeks post injury, date began working with restrictions at new job
- D. Yes, 52 weeks post injury, date of DD exam
- E. No, not at MMI



Case 1 – Upper Extremity MMI/IR *The Sequel*

Question for DD to
consider in the exam:

On MMI date what is
whole person IR?

Show your work!



Case 1 – Upper Extremity MMI/IR *The Sequel*

On date of MMI, what is whole person IR?

- A. 5%
- B. 8%
- C. 11%
- D. 18%



Impairment Rating

- Shoulder ROM from DD exam to reflect the CONDITION at MMI prior to DD exam
- Clinical condition is the same
- ***Explain in your report!***

Case 1 - Upper Extremity MMI/IR

The Sequel

DD Physical Exam - 52 Weeks Post Injury

- Shoulder ROM
- Flexion 155°
- Extension 28°
- Abduction 150°
- Adduction 30°
- IR 40°
- ER 50°

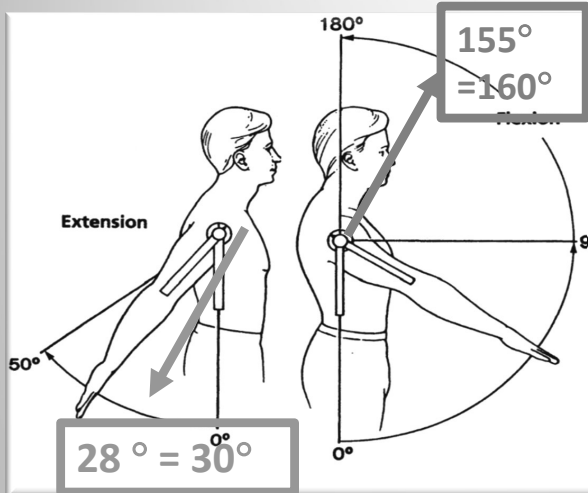

Fig. 36, p. 42
Shoulder Extension and Flexion

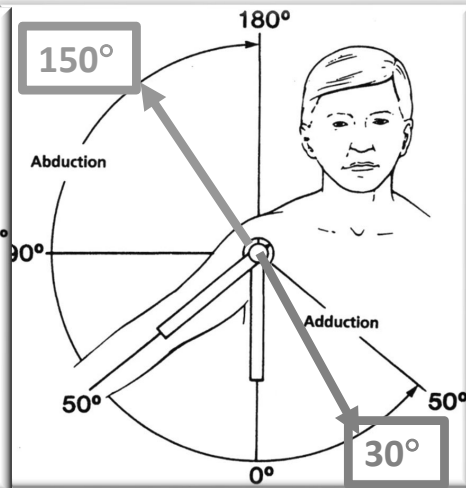

Fig. 39, p. 43 Shoulder Abduction and Adduction

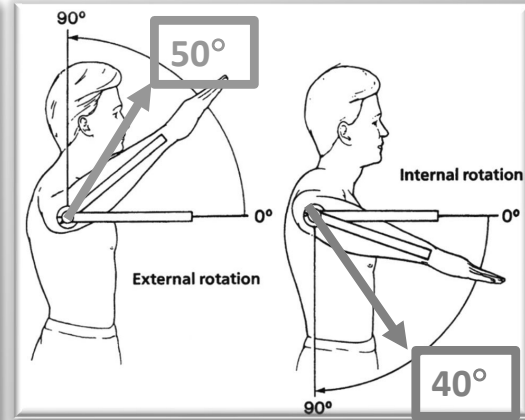

Fig. 42, p. 44 - Shoulder External & Internal Rotation

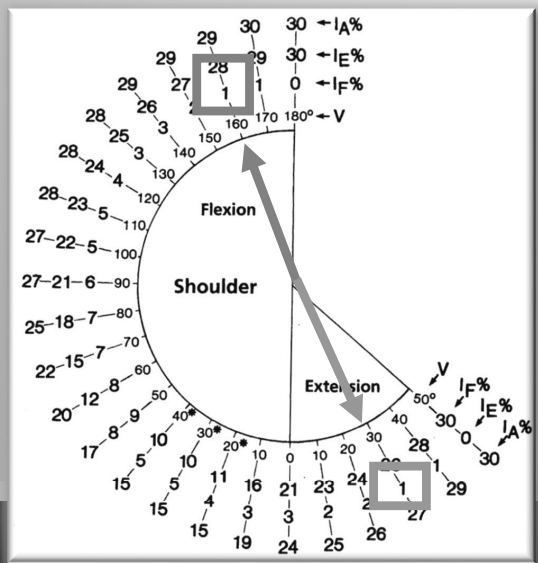

Fig. 38, p. 43

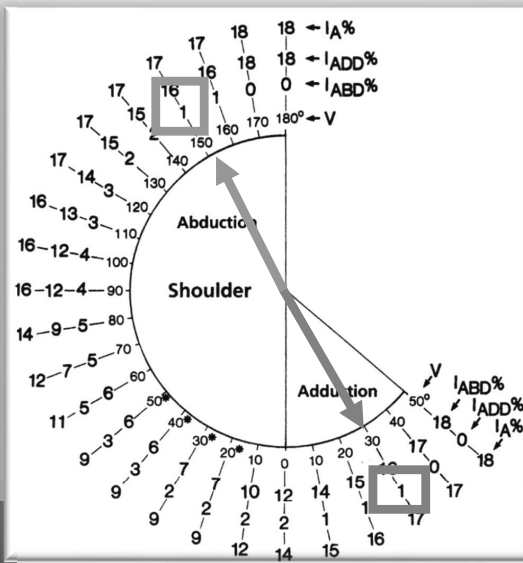

Fig. 41, p. 44

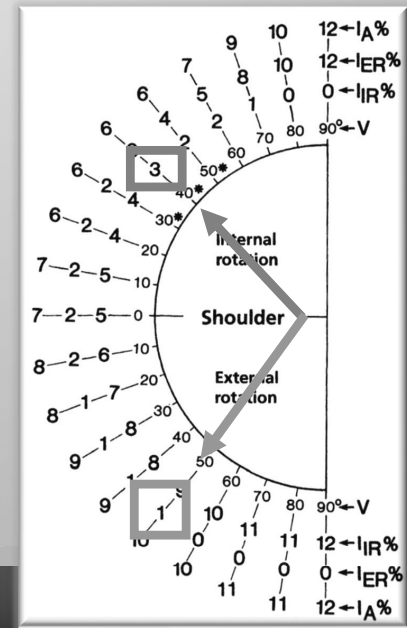
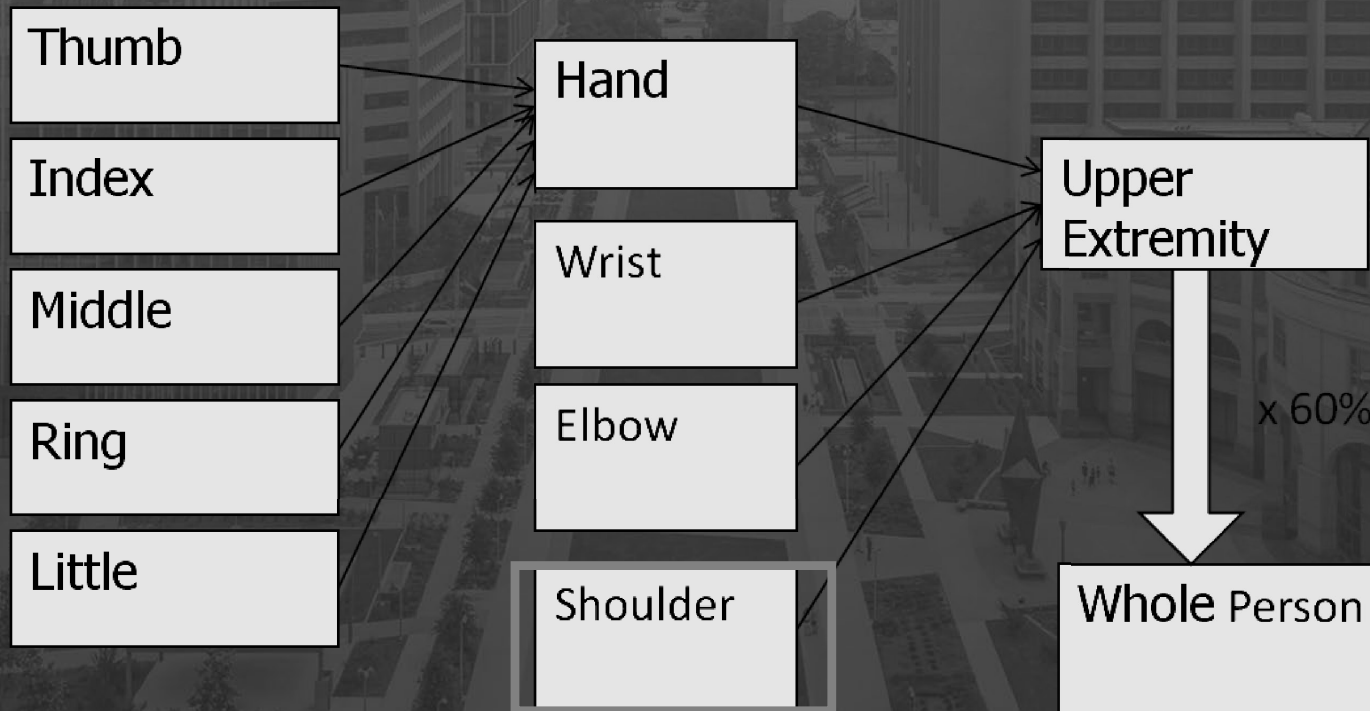

Fig. 44, p. 45

Shoulder		Flexion	Extension	Ankylosis	IMP%		
	Angle°	160°	30°		2%		
	IMP%	1%	1%				
		Add	Abd	Ankylosis	IMP%		
	Angle°	30°	150°		2%		
	IMP%	1%	1%				
		Int Rot	Ext Rot	Ankylosis	IMP%		
	Angle°	40°	50°		4%		
	IMP%	3%	1%				
	Add IMP% F/E + Add/Abd + IR/ER =				8% UE	[1]	IMP% :

Whole Person Concept Upper Extremity



Convert Upper Extremity to Whole Person *Table 3, Page 20*

% Impairment of		% Impairment of		% Impairment of				
Upper extremity	Whole person	Upper extremity	Whole person	Upper extremity	Whole person			
0	=	0	35	=	21	70	=	42
1	=	1	36	=	22	71	=	43
2	=	1	37	=	22	72	=	43
3	=	2	38	=	23	73	=	44
4	=	2	39	=	23	74	=	44
5	=	3	40	=	24	75	=	45
6	=	4	41	=	25	76	=	46
7	=	4	42	=	25	77	=	46
8	=	5	43	=	26	78	=	47
9	=	5	44	=	26	79	=	47
10	=	6	45	=	27	80	=	48
11	=	7	46	=	28	81	=	49
12	=	7	47	=	28	82	=	49
13	=	8	48	=	29	83	=	50
14	=	8	49	=	29	84	=	50
15	=	9	50	=	30	85	=	51
16	=	10	51	=	31	86	=	52
17	=	10	52	=	31	87	=	52
18	=	11	53	=	32	88	=	53
19	=	11	54	=	32	89	=	53
20	=	12	55	=	33	90	=	54
21	=	13	56	=	34	91	=	55
22	=	13	57	=	34	92	=	55
23	=	14	58	=	35	93	=	56
24	=	14	59	=	35	94	=	56
25	=	15	60	=	36	95	=	57
26	=	16	61	=	37	96	=	58
27	=	16	62	=	37	97	=	58
28	=	17	63	=	38	98	=	59
29	=	17	64	=	38	99	=	59
30	=	18	65	=	39	100	=	60
31	=	19	66	=	40			

8% UE = 5% Whole Person

Figure 1. Upper Extremity Impairment Evaluation Record–Part 2 (Wrist, elbow, and shoulder) Side R L

Name Edvard Munch Age 24 Sex M F Dominant hand R L Date _____

Occupation Painter Diagnosis Right Rotator cuff tear

Abnormal motion					Other disorders	Regional impairment %	Amputation	
Record motion, ankylosis and impairment %					List type & impairment %	* Combine [1] + [2]	Mark level & impairment %	
Wrist	Flexion	Extension	Ankylosis	IMP%				
	Angle°							
	IMP%							
	RD	UD	Ankylosis	IMP%				
	Angle°							
	IMP%							
Add IMP% F/E + RD/UD =				[1]	IMP% =	[2]		
Elbow	Flexion	Extension	Ankylosis	IMP%				
	Angle°							
	IMP%							
	Pro	Sup	Ankylosis	IMP%				
	Angle°							
	IMP%							
Add IMP% F/E + PRO/SUP =				[1]	IMP% =	[2]		
Shoulder	Flexion	Extension	Ankylosis	IMP%				
	Angle°	160	30					2
	IMP%	1	1					
	Add	Abd	Ankylosis	IMP%				
	Angle°	30	150				2	
	IMP%	1	1					
	Int Rot	Ext Rot	Ankylosis	IMP%				
	Angle°	40	50				4	
	IMP%	3	1					
	Add IMP% F/E + Add/Abd + IR/ER =						8%	[1]

FIGURE 1,
PART 2
Top half of form....

I. Amputation impairment (other than digitis)	=	
II. Regional impairment of upper extremity • (Combine hand _____% + wrist _____% + elbow _____% + shoulder _____%)	=	
III. Peripheral nerve system impairment	=	
IV. Peripheral vascular system impairment	=	
V. Other disorders (not included in regional impairment)	=	
Total upper extremity impairment (• Combine I + II + III + IV + V)	=	8%
Impairment of the whole person (Use Table 3 p. 20)	=	5%

If both limbs are involved, calculate the whole-person impairment for each on a separate chart and *combine* the percents (Combined Values Chart).

FIGURE 1,
PART 2
Bottom half of
form....

Upper Extremity Section 3.1m - Other Disorders

These are not commonly used but should be addressed.

- These are recorded in the column to the RIGHT of the column that records ROM on Figure 1 – Part 2. Denoted as ***“Other Disorders”***.
- In most cases, the chosen value from the Tables 19 – 30 (for the type of loss of function), are multiplied by the Relative Value of a specific joint as per Table 18

Upper Extremity Section 3.1m - Other Disorders

"It is emphasized that impairments from the disorders considered in the section are usually estimated by using other criteria. The criteria described in this section should be used only when the other criteria have not adequately encompassed the extent of the impairments." Section 3.1m, page 58 AMA Guides, 4th Edition

Upper Extremity Other Disorders

Section 3.1m

When to use this section:

- Occasions that ROM losses do not adequately explain the functional loss to an upper extremity functional unit.
- Digit impairment assessments that allow combining rotational or lateral deviation deformities to ROM or other digit losses
- Resection or replacement arthroplasties, WHEN they are performed for the compensable injury.
- Other miscellaneous considerations (a later case)

What About Crepitation noted on the DD exam?

Text Above Table 18, Page 58

The evaluator must take care to avoid duplication of impairments when other findings, such as synovial hypertrophy, carpal collapse with arthritic changes, or limited motion, are present. Those findings might indicate a greater severity of the same pathologic process and take precedence over evaluation of joint crepitation, which should not be rated in that instance.

Upper Extremity Other Disorders

Section 3.1m

Section 3.1m methods that are “Stand-alone”,
when ROM is full or normal

- Joint crepitation
- Synovial hypertrophy
- Persistent Joint Subluxation or Dislocation
- Musculotendinous Impairments (page 63)

Upper Extremity Other Disorders

Section 3.1m

Section 3.1m methods that may be COMBINED with other impairments of the joint IF present.

- **Digit lateral deviation / rotational deformity**
 - ✓ Not uncommon with fractures of the digits
- Joint Instability
- Wrist and Elbow joint radial and ulnar deviation
- Carpal Instability

Case 1 - Upper Extremity MMI/IR

The Sequel

What about acromioplasty and Table 27 on page 61?

- **Acromioplasty** is changing the shape of the acromion – specifically the rotator cuff side
- By definition, a **Resection Arthroplasty** of the AC joint is aka **Distal Clavicle Resection** (DCR). This requires resection of the distal clavicular portion of AC joint

Case 1 - Upper Extremity MMI/IR

The Sequel

Acromioplasty vs. Distal Clavicle Resection

- Carefully review and cite relevant portions of the operative report to assist in your determination of whether a SAD vs DCR was performed
- What **IF** the operative report demonstrates that the injured employee had undergone resection arthroplasty (DCR) of the distal clavicle?
 - ✓ Consider the information on the following slides

APD 151158-s

*“The language contained on page 3/58 is ambiguous, whereas the language on page 3/62 provides more clear instruction regarding the rating of arthroplasty procedures. Therefore, we hold that impairment for a distal clavicle resection arthroplasty that was received as treatment for the **compensable injury** results in 10% UE impairment under Table 27, which is then combined with ROM impairment, if any, as provided by the AMA Guides.”*

APD 221683 [December 19, 2022]

The case in THIS APD was one in which the DD determined the compensable injury was a **right shoulder contusion, right shoulder sprain/strain**, cervical sprain, and other upper extremity diagnoses.

- A surgery was performed, which included a DCR
- The DD assigned an IR for shoulder ROM **and** a distal clavicle resection
- The AP reversed the ALJ's determination that the claimant's date of MMI and the IR (which were based on the shoulder surgery that included a distal clavicle resection) and remanded the MMI / IR issue back to the ALJ for further action consistent with this decision.

DISTAL CLAVICLE RESECTION SUMMARY

- **There should be three factors in your decision making as to inclusion of a DCR with ROM losses.**
 1. Did the compensable injury include an injury to the AC joint or objective evidence that there was aggravation of moderate / severe OA of the AC joint?
 2. When does the ODG indicate that a DCR should be done?
 3. IF NOT, are there any case specific details or other EBM that would be more persuasive than the EBM in the ODG that would necessitate a DCR?
- **EXPLAIN your rationale for when you INCLUDE it or DO NOT INCLUDE it.**

**Any Questions about
Case 1 - UE MMI/IR
*The Sequel?***



Case 2 – Upper Extremity MMI/IR

- 25 year-old male oil field worker sustained a crush injury to left hand

Case 2 - Upper Extremity MMI/IR

- Seen in ER date of injury and underwent surgery date of injury
- Traumatic amputation of left index finger at metacarpal phalangeal joint
- Fractures of proximal phalanx of left thumb and proximal phalanx of middle finger treated with pin fixation

Case 2 - Upper Extremity MMI/IR

- 24 post op OT visits
- OT discharge **40 weeks post injury**
 - Well healed index finger amputation
 - Index MP flexion 90° and extension + 20°
 - Thumb ROM
 - IP flexion 35° and extension -15°
 - MP flexion 40° and extension - 05°
 - Radial Abduction 40°
 - Adduction and opposition not measured

Case 2 - Upper Extremity MMI/IR

- OT discharge **40 weeks post injury**
 - Middle finger ROM
 - DIP flexion 45° and extension -15°
 - PIP flexion 55° and extension - 05°
 - MP flexion 60° and extension -10°
 - Sensation “decreased” over the palmar surface of the middle finger from the PIP joint distally.

Case 2 - Upper Extremity MMI/IR

- Treating doctor follow-up **40 weeks post injury**
 - Healed thumb and finger fractures and index finger wound site
 - As per the doctor *“more time needed for spontaneous healing of digital nerve injury to middle finger”*

Case 2 - Upper Extremity MMI/IR

- Treating doctor follow-up **52 weeks post injury**
 - Healed middle finger and thumb fractures and index finger wound site
 - Numbness of the middle finger unchanged over the last 3 months
 - Thumb and middle finger ROM *“same as prior visit after completing OT”*
 - Returned to work at new job
 - Continue gabapentin, follow-up 3 months

Case 2 - Upper Extremity MMI/IR

DD Physical Exam **60 Weeks Post-Injury**

- Taking gabapentin
- Working full time at new job
- Continued numbness middle finger
- Well healed scars, no redness/swelling

Case 2 - Upper Extremity MMI/IR

DD Physical Exam 60 Weeks Post-Injury (cont'd)

- **Left thumb**

- IP flexion 40° , extension -10°
- MP flexion 40° , MP extension 0°
- Radial Abduction = 35°
- Lack of adduction = 3 cm
- Able to oppose to 6 cm from the palm
- 6 mm of 2-point discrimination entire palmar aspect of the radial and ulnar side of the digit

Case 2 - Upper Extremity MMI/IR

DD Physical Exam 60 Weeks Post-Injury (cont'd)

- **Left index finger** amputation at MID-Proximal Phalanx
- **Left middle finger**
 - **ROM**
 - DIP flexion 50° and extension -20°
 - PIP flexion 60° and extension -10°
 - MP flexion 60° and extension -10°
 - **Sensation** >15 mm of 2-point discrimination entire palmar aspect of finger from PIP joint distally

Case 2 – Upper Extremity MMI/IR

Based on medical records and physical exam, what is the compensable injury for certifying MMI and IR?

130.1(c)(3)



Case 2 – Upper Extremity MMI/IR

What is compensable injury for certifying MMI and IR?

- A. Left hand crush injury
- B. Fracture of proximal phalanx of thumb
- C. Traumatic amputation of left index finger
- D. Fracture proximal phalanx of middle finger with digital nerve injury
- E. A, B, C, D

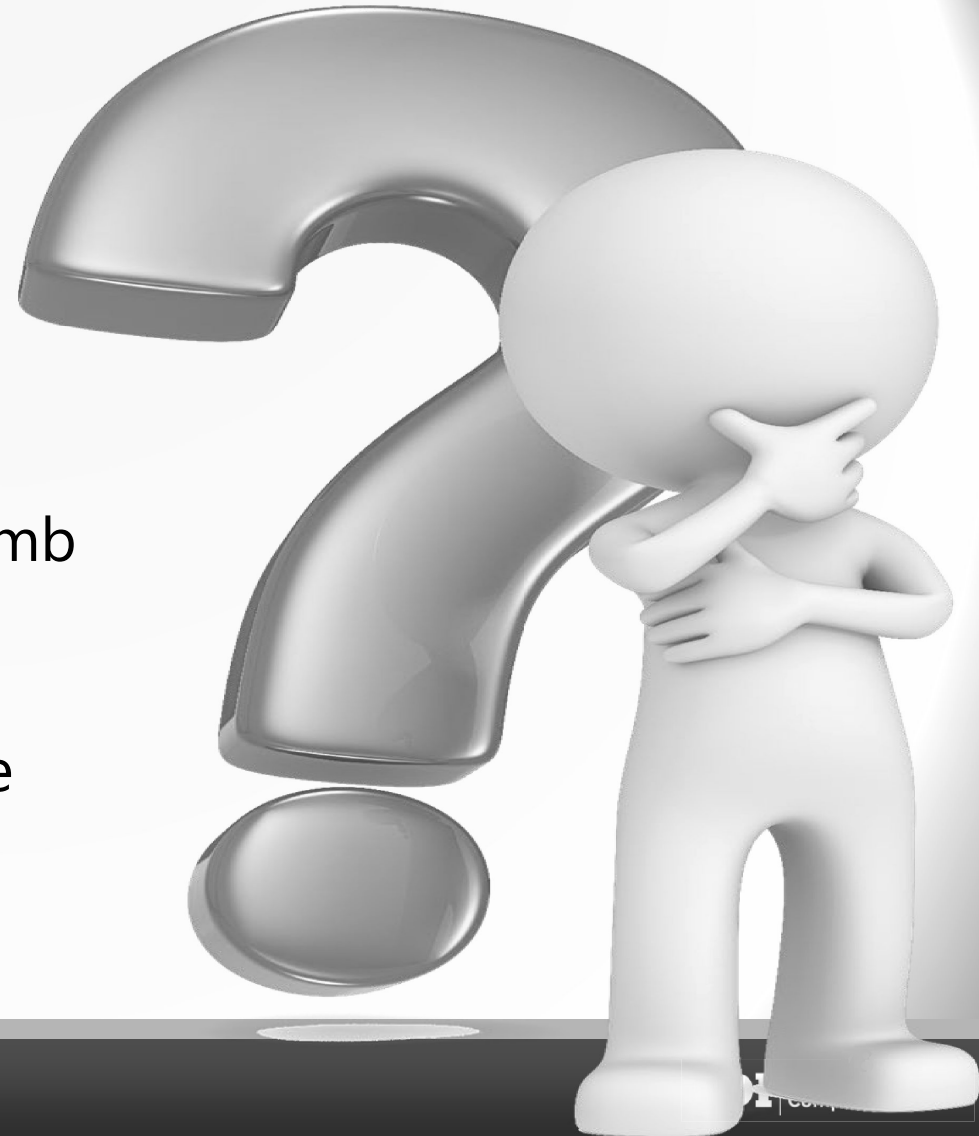

Case 2 – Upper Extremity MMI/IR

**Has MMI been reached?
If so, on what date?**

- A. Yes, 40 weeks post injury, date of OT discharge and treating doctor follow-up
- B. Yes, 52 weeks post injury, date of treating doctor follow-up
- C. Yes, 60 weeks post injury, date of DD exam
- D. No, not at MMI

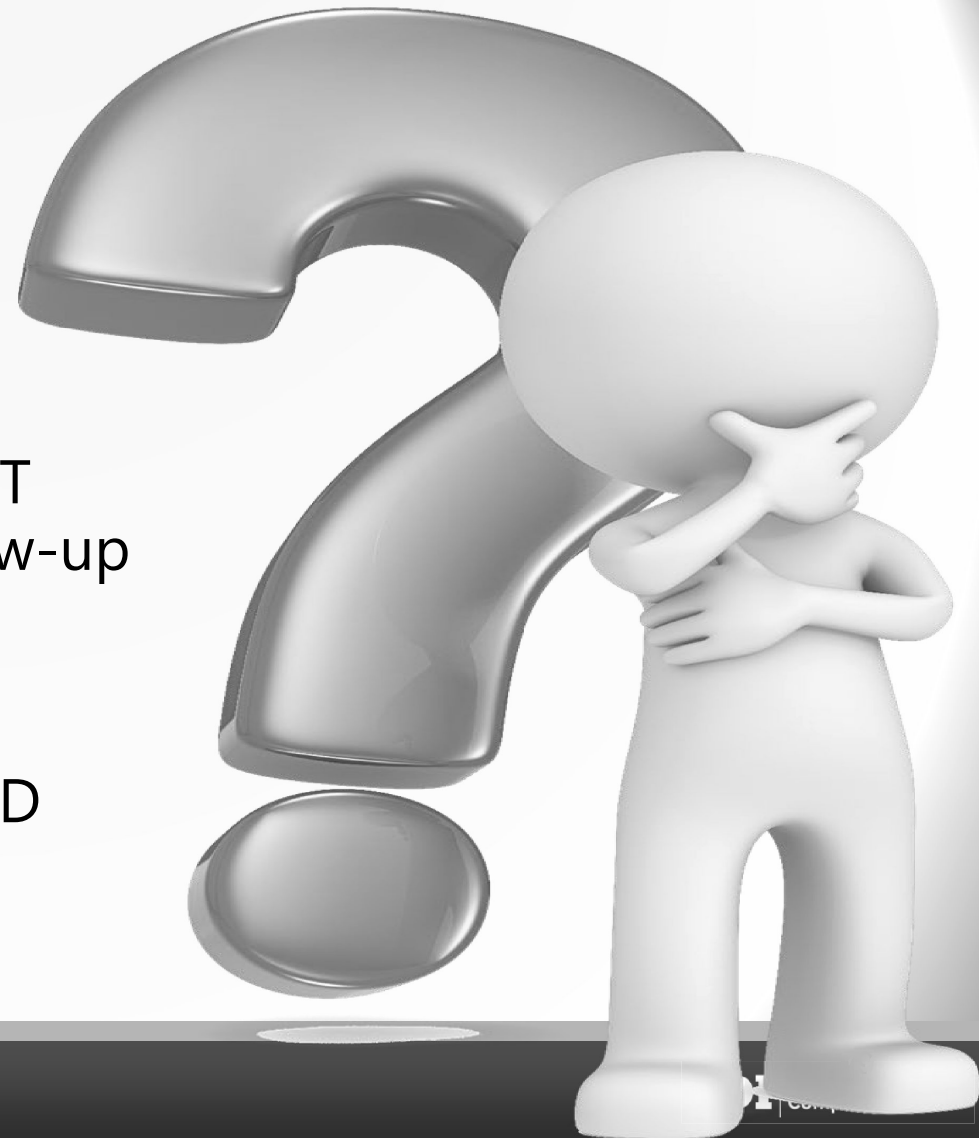

Case 2 – Upper Extremity MMI/IR

Question for DD to
consider in the exam:

On MMI date what is
whole person IR?

Show your work!



Case 2 – Upper Extremity MMI/IR

On date of MMI what is
whole person IR?

- A. 38%
- B. 34%
- C. 20%
- D. 17%



Case 2 - Upper Extremity MMI/IR

WHAT values are you using?

- ✓ The condition of the IE at 40 weeks is the same / similar to the condition at 60 weeks.
- ✓ Some of the details are missing from the condition at 40 weeks, so it is reasonable that the DD chose to use their measurements from DD exam.
- ✓ The DD also knows that their exam was done in strict accordance with the positions of measurements as per the AMA 4th, so chose to use their measurements.
- ✓ **The DD explains this in their report.**

Case 2 - Upper Extremity MMI/IR

What are you rating?

- Thumb ROM
- Index finger amputation
- Middle finger
 - ROM
 - Sensory loss

Use Figure 1 – Part 1!

Case 2 – Upper Extremity MMI/IR

Thumb ROM

Use Figure 1 – Part 1!

Thumb ROM - ADD

IP flexion 40°, extension -10°



MP flexion 40°, MP extension 0°



CMC Abduction 35 °



CMC Lack of adduction = 3 cm



CMC Able to oppose to 6 cm from palm

Thumb MP joint Figure 13, Page 27

MP flexion **40°** = 2%

MP extension **0°** = 0%

Add 2% + 0% = 2%

(MP thumb ROM
impairment)

ADD within a joint

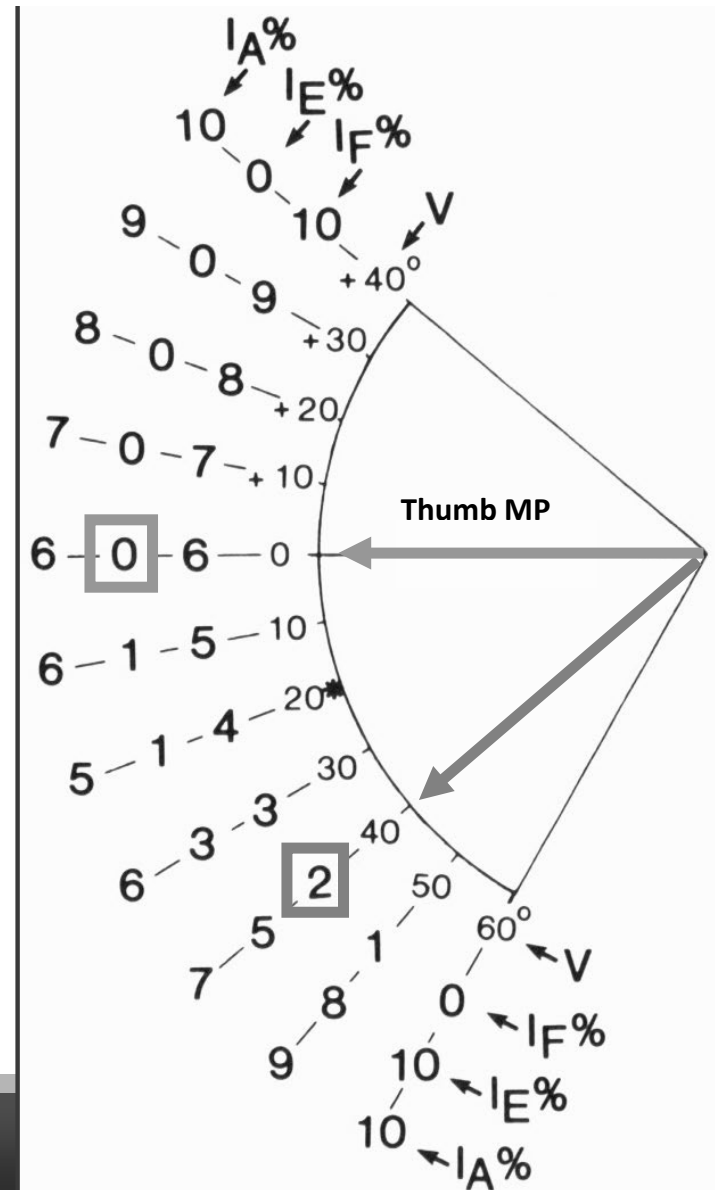

CMC - Radial Abduction

Figure 15, pg. 29

1. Measure and record the largest possible angle in degrees formed by the first and second metacarpals during maximum active radial abduction
2. The normal range of radial abduction is from 0° to 50° .
3. Consult Table 6 to determine the percentage of thumb impairment

Figure 15. Radial Abduction of Thumb, Measured in Degrees.

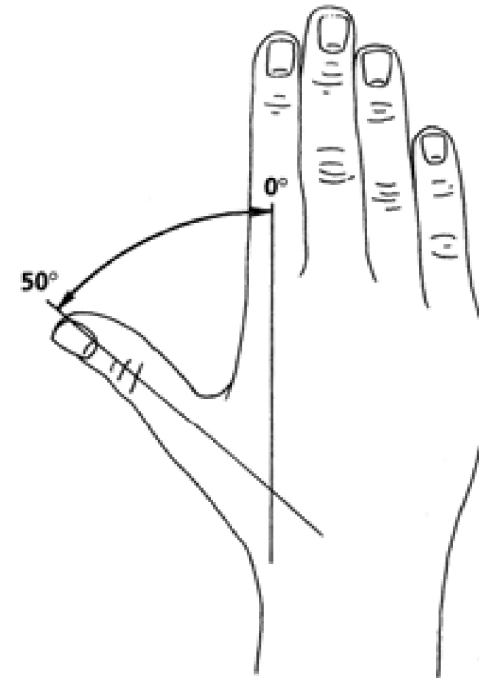

CMC - Radial Abduction Table 6, Page 28

Radial Abduction

70° = 0% thumb impairment

Measured radial abduction (°)	% Thumb impairment due to	
	Abnormal motion	Ankylosis
0	10	10
10	9	10
20	7	10
30	3	10
40	1	10
50	0	10

35°

CMC Adduction.

Measure **lack of** adduction

1. **Measure and record the smallest possible distance** in centimeters from the flexor crease of the thumb IP joint to the distal palmar crease over the MP joint of the little finger
2. The normal range is from 8 to 0 cm
3. Consult Table 6 to determine the percentage of thumb impairment

Note: Lack of 8 cm of adduction = 100% impairment

Figure 14, Page 28

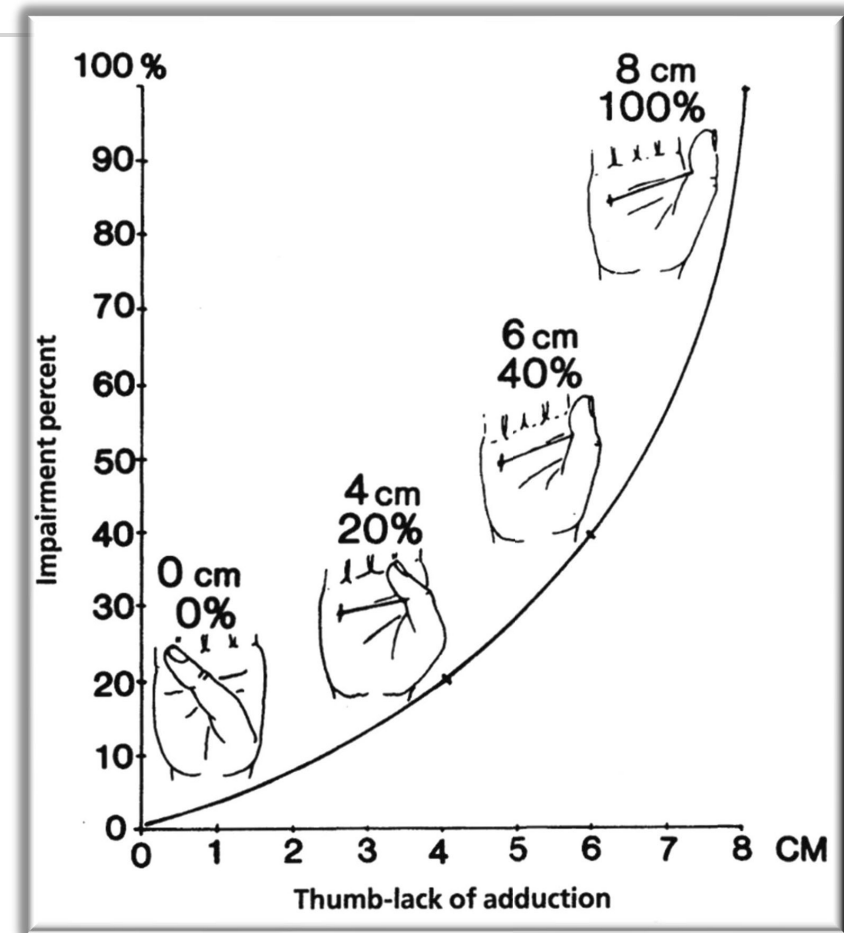

CMC - Adduction

Measure Adduction

3 cm measured lack of adduction = 3 % thumb impairment

Table 5, Page 28

Measured lack of adduction (cm)	% Thumb impairment due to	
	Abnormal motion	Ankylosis
8	20	20
7	13	19
6	8	17
5	6	15
4	4	10
3	3	15
2	1	17
1	0	19
0	0	20

CMC – Opposition

Figure 16, Page 29

Measure Thumb Opposition

1. **Measure and record the largest possible distance** in centimeters from the flexor crease of the thumb IP joint to the distal palmar crease directly over the third MP joint.
2. Normal range is from 0 to 8 cm.
3. Consult Table 7 to determine the percentage of thumb impairment

Figure 16. Linear Measurements of Thumb Opposition (cm) at Various Positions and Impairment Curve for Lack of Opposition.*

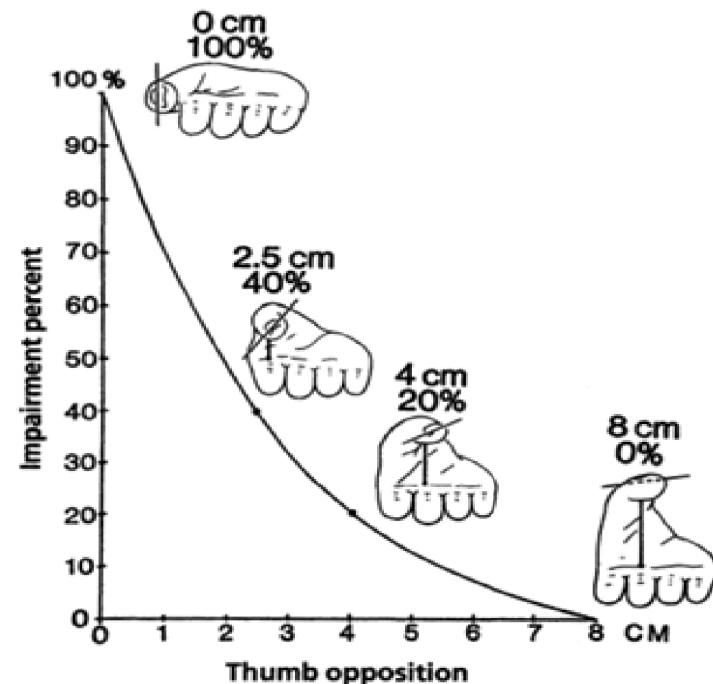

Table 7, Page 29

Measure Opposition

6 cm opposition = 3% thumb impairment

Measured opposition (cm)	% Thumb impairment due to	
	Abnormal motion	Ankylosis
0	45	45
1	31	40
2	22	36
3	13	31
4	9	27
5	5	22
6	3	24
7	1	27
8	0	29

Abnormal Motion Thumb

Five areas of motion

- **Add** impairment losses within a joint for all UE Joints
- **Add** impairment losses of *different* joints of thumb (only)

❖ ***Use Figure 1, Part 1!***

Thumb ROM Impairment

ADD ALL IMPAIRMENTS within JOINT, and JOINT to Joint in THUMB

- IP flexion (40°) 3% +
IP extension (-10°) 2% = **5%**
- MP flexion (40°) 2% +
IMP extension (0°) 0% = **2%**
- CMC Radial Abduction 35° = **1%**
- CMC Adduction lacks 3 cm = **3%**
- CMC Opposition to 6 cm from palm = **3%**
- Total: 5% + 2% + 1% + 3% + 3% = **14 % thumb impairment**
HOLD THIS VALUE OF THE DIGIT to determine HAND VALUE

Convert Digit to Hand

Table 1, Page 18

% Impairment of Thumb		% Impairment of Hand		% Impairment of Index or middle finger		% Impairment of Ring or little finger	
0- 1 = 0	2- 3 = 1	4- 6 = 2	7- 8 = 3	9- 11 = 4	12- 13 = 5	14- 16 = 6	17- 18 = 7
19- 21 = 8	22- 23 = 9	24- 26 = 10	27- 28 = 11	29- 31 = 12	32- 33 = 13	34- 36 = 14	37- 38 = 15
47- 48 = 19	49- 51 = 20	52- 53 = 21	54- 56 = 22	57- 58 = 23	59- 61 = 24	62- 63 = 25	64- 66 = 26
93- 97 = 19	98-100 = 20						

14% thumb impairment = 6% hand

**Case 2 –
Upper Extremity
MMI/IR**

Index finger amputation

Use Figure 1 – Part 1!

Index Finger Amputation

Figure 17, pg. 30

- DIP joint = 45% length of digit
- PIP joint = 80% length of digit
- DIP joint = MP joint = 100% length of digit
- MID – Proximal phalanx = 90% index finger impairment

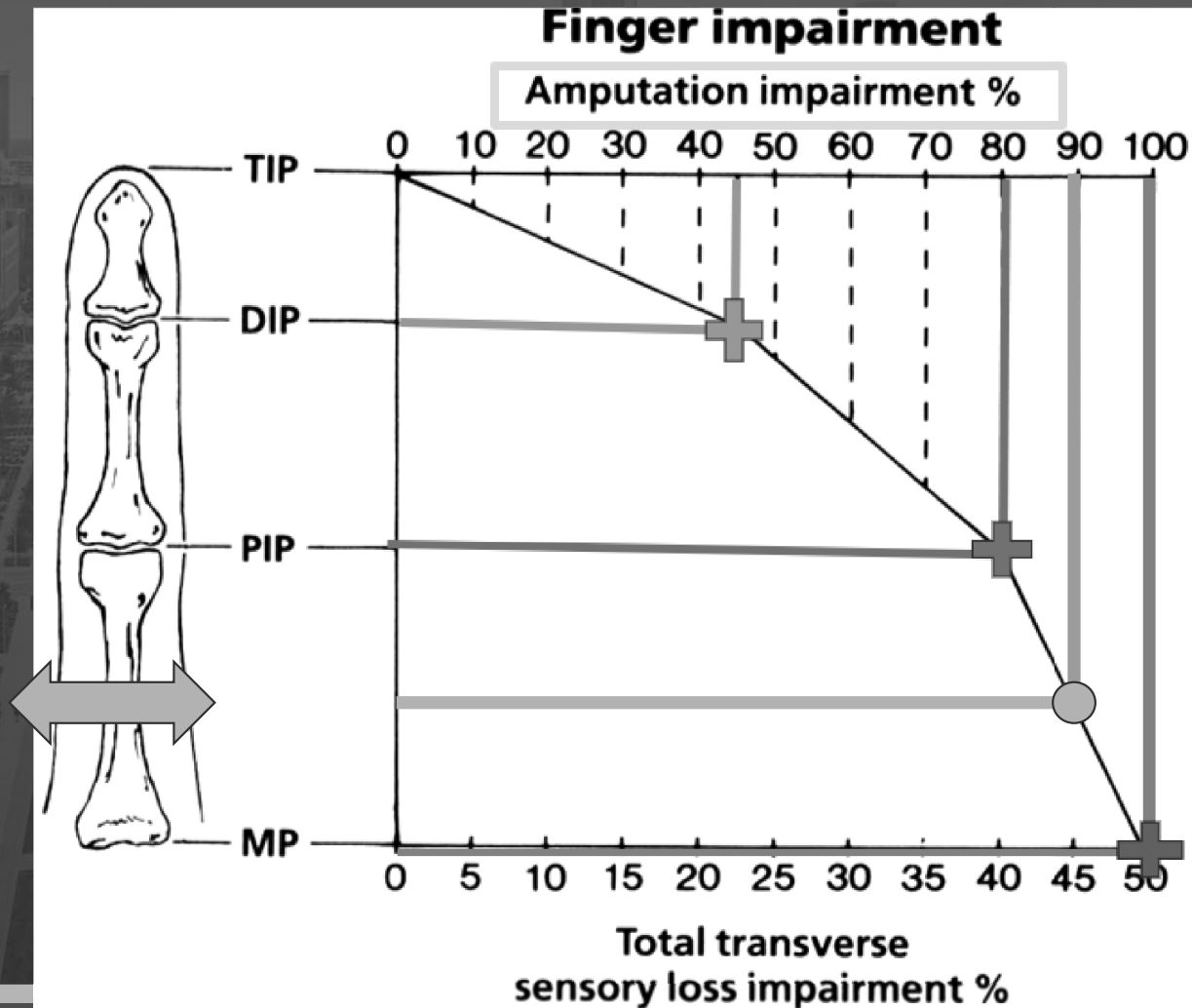

Index Finger Impairment

- Amputation Value at Mid-Proximal Phalanx = 90 % of the digit
- MP joint ROM was normal

90 % index finger impairment

SAVE THIS VALUE OF THE DIGIT to determine HAND VALUE

Convert Digit to Hand

Table 1, Page 18

% Impairment of		% Impairment of		% Impairment of	
Thumb	Hand	Index or middle finger	Hand	Ring or little finger	Hand
0- 1 =	0	0- 2 =	0	0- 4 =	0
2- 3 =	1	3- 7 =	1	5- 14 =	1
4- 6 =	2	8- 12 =	2	15- 24 =	2
7- 8 =	3	13- 17 =	3	25- 34 =	3
9- 11 =	4	18- 22 =	4	35- 44 =	4
12- 13 =	5	23- 27 =	5	45- 54 =	5
14- 16 =	6	28- 33 =	6	55- 64 =	6
				65- 74 =	7
				75- 84 =	8
				85- 94 =	9
				95-100 =	0
29- 31 =	12	58- 62 =	12		
32- 33 =	13	63- 67 =	13		
34- 36 =	14	68- 72 =	14		
37- 38 =	15	73- 77 =	15		
39- 41 =	16	78- 82 =	16		
42- 43 =	17	83- 87 =	17		
44- 46 =	18	88- 92 =	18		
47- 48 =	19	93- 97 =	19		
49- 51 =	20	98-100 =	20		
52- 53 =	21				
54- 56 =	22				
57- 58 =	23				
59- 61 =	24				
62- 63 =	25				
64- 66 =	26				

90% index finger impairment = 18% hand

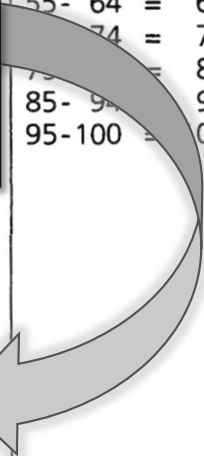

Case 2 – Upper Extremity MMI/IR

Middle finger

- ROM
- Sensory loss

Use Figure 1 – Part 1!

Middle Finger

- Middle finger ROM
 - DIP flexion $50^\circ = 10\% +$
 - DIP extension $-20^\circ = 4\% = \mathbf{14\%}$
 - PIP flexion $60^\circ = 24\% +$
 - PIP extension $-10^\circ = 3\% = \mathbf{27\%}$
 - MP flexion $60^\circ = 17\% +$
 - MP extension $-10^\circ = 7\% = \mathbf{24\%}$
- Combine: $\mathbf{27\%}$ cw $\mathbf{24\%} = 45\%$
 - Then combine 45% cw $\mathbf{14\%} = \mathbf{53\%}$ middle finger

ROM = 53% middle finger

SAVE this value to combine with the OTHER functional impairment of this digit BEFORE determining HAND value.

DIP Flexion-Extension

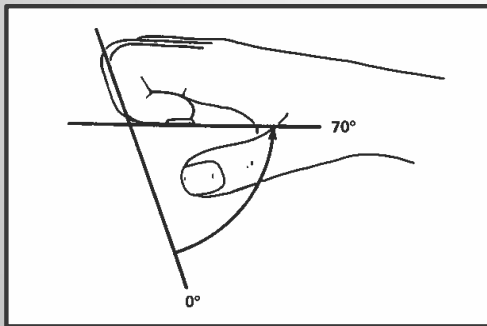

Figure 18, page 32

PIP Flexion-Extension

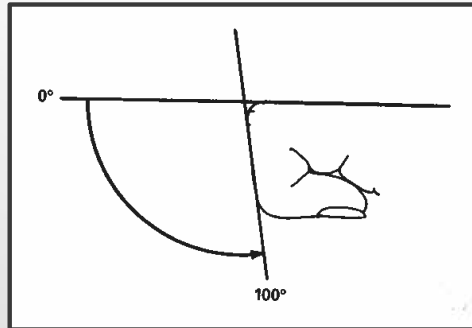

Figure 20, page 33

MP Flexion-Extension

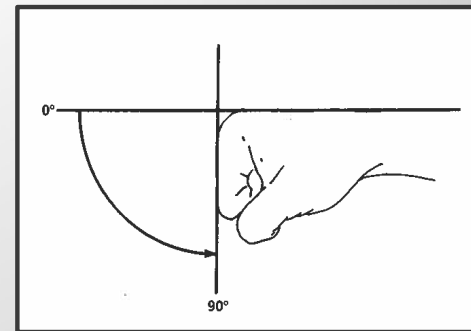

Figure 22, page 34

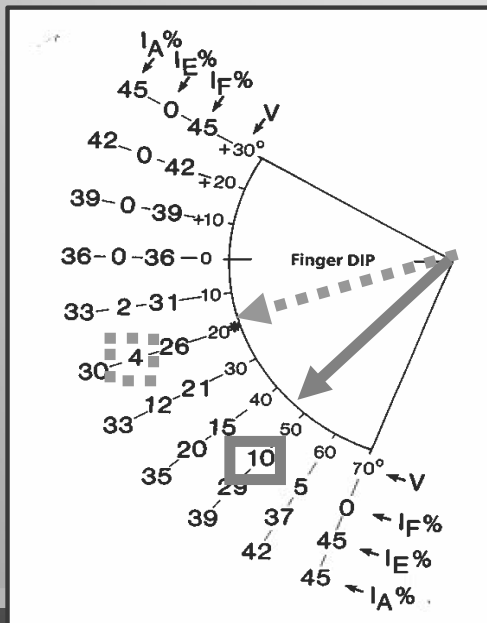

Figure 19, page 32

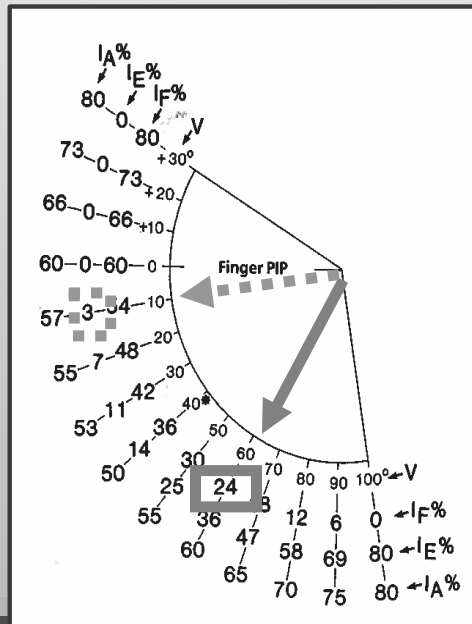

Figure 21, page 33

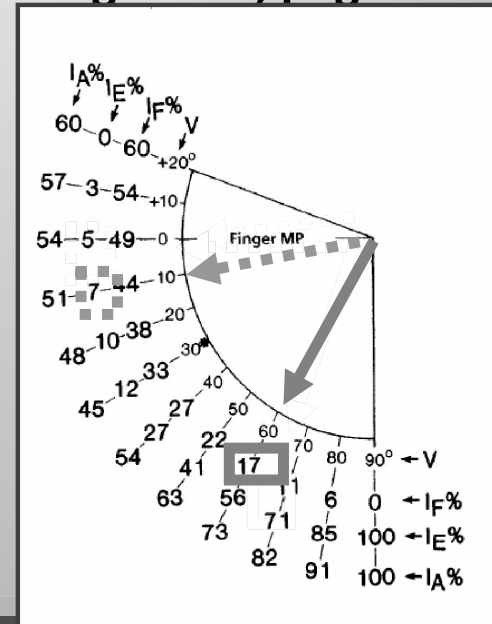

Figure 23, page 34

Middle Finger – Sensory Loss

Middle finger sensation:

- Finger sensation > 15 mm of 2- point discrimination entire palmar aspect of the finger from PIP joint distally
 - See page 24 for the thumb (beneath Figure 7) and page 30 (beneath Figure 17) for the other digits for an explanation of partial vs TOTAL sensory loss and how to determine %
- Total transverse sensory loss of 80% length of the middle finger = 40% middle finger sensory loss (50 % of the amputation value)

UE Case 2 Middle Finger Sensory Loss

Figure 17, Page 30

Measure length of sensory loss

>15 mm = total loss

40% middle finger

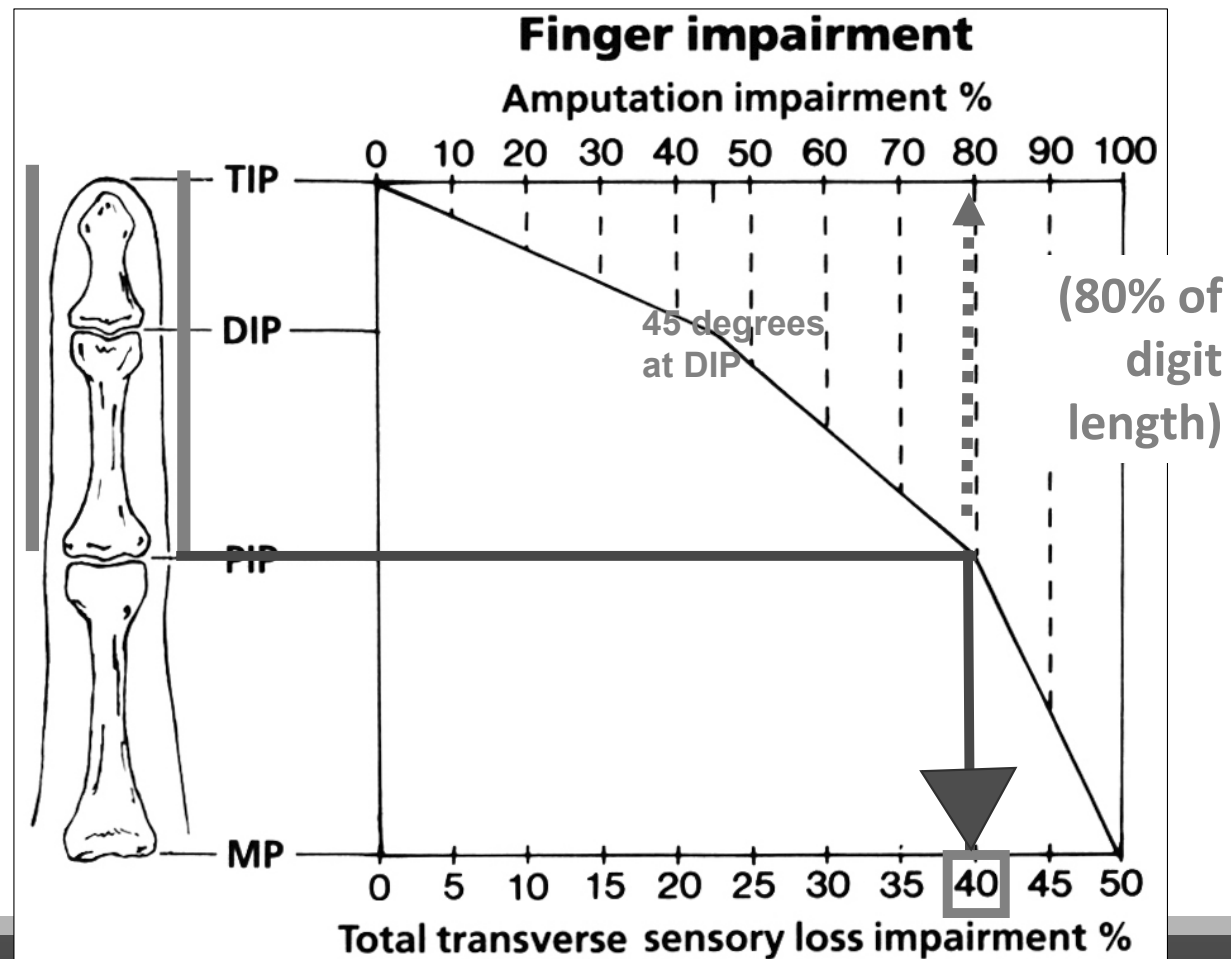

Sensory Loss of Digits

Several steps in determining % of sensory loss, as it relates to the digits.

Quality of Loss –

- Partial vs. Total

Types of Loss –

- Transverse vs. Longitudinal

Length of Loss

Thumb vs. other Digits

Sensory Loss of Digits

Determine **QUALITY** of Loss, page 21

- Determine by two-point discrimination exam
- > 15 mm = **total** sensory loss, 100% sensory impairment
- 15 mm through 7 mm = **partial** sensory loss, 50% sensory impairment
- ≤ 6 mm **normal**, 0% sensory impairment

Sensory Loss of Digits

TYPE OF LOSS

Transverse Loss – this case

- Loss of function in **both digital nerves (entire palmar distribution) at the SAME level**
- IF 100% (TOTAL) sensory loss, it receives 50% of the amputation value at that level
 - Fingers - Figure 17, page 30 (this case)
 - Thumb - Figure 7, page 24

Middle Finger

Use Figure 1

- **Combine ROM and sensory loss for this digit**
- 40% for complete transverse sensory loss COMBINED with
- 53% for ROM loss

= 72% middle finger

**IF there was a lateral deviation or rotational deformity as a result of the fractures, it would also be combined at the level of the digit.*

SAVE THIS VALUE OF THE DIGIT to determine HAND VALUE

Convert Digit to Hand

Table 1, Page 18

**72% middle finger impairment =
14% hand**

% Impairment of Thumb		% Impairment of Hand		% Impairment of Index or middle finger		% Impairment of Ring or little finger	
0-1	= 0	0-2	= 0	0-4	= 0	0-4	= 0
2-3	= 1	3-7	= 1	5-14	= 1	5-14	= 1
4-6	= 2	8-12	= 2	15-24	= 2	15-24	= 2
7-8	= 3	13-17	= 3	25-34	= 3	25-34	= 3
9-11	= 4	18-22	= 4	35-44	= 4	35-44	= 4
		23-27	= 5	45-54	= 5	45-54	= 5
		28-32	= 6	55-64	= 6	55-64	= 6
		33-37	= 7	65-74	= 7	65-74	= 7
		38-42	= 8	75-84	= 8	75-84	= 8
		43-47	= 9	85-94	= 9	85-94	= 9
24-26	= 10	48-52	= 10	95-100	= 10	95-100	= 10
27-28	= 11	53-57	= 11				
29-31	= 12	58-62	= 12				
32-33	= 13	63-67	= 13				
34-36	= 14	68-72	= 14				
37-38	= 15	73-77	= 15				
39-41	= 16	78-82	= 16				
42-43	= 17	83-87	= 17				
44-46	= 18	88-92	= 18				
47-48	= 19	93-97	= 19				
49-51	= 20	98-100	= 20				
52-53	= 21						
54-56	= 22						
57-58	= 23						
59-61	= 24						
62-63	= 25						
64-66	= 26						

Sensory Loss of Digits – What About Longitudinal Sensory Loss?

Longitudinal Loss

- Each digital nerve (if more than one) is calculated separately.
 - **FOUR factors:**
 - ✓ Which digit (Determines Table 8 vs. Table 9)
 - ✓ Radial or Ulnar side
 - ✓ Length of loss
 - ✓ Partial or total loss
 - ❖ **ADD** the IR from each side if more than one.
- 3rd Exception to Combining in the UE***

Sensory Loss of Digits – What About Longitudinal Sensory Loss?

Different Types of Sensory Loss

• **Longitudinal Loss**

- **Impairment value varies as to side injured (radial vs. ulnar side of digit)**
- Be sure to read sections on proper use of Tables
- Thumb/ Little – Table 4, page 25 and Table 8, page 31
- Index, middle, ring – Table 9, page 31

What About Impairment due to Lateral Deviation or Rotational Deformity?

Not in this case, but there are occasions where fractures of the digit result in Lateral Deviation or Rotational Deformity

- These are under **section 3.1m: Tables 21** = Lateral Deviation AND **Table 22** = Rotational Deformity
- The heading of the far-right column of Tables 21 AND 22 says **% DIGIT impairment.**
- THAT value is taken directly to Fig 1 Part 1 to be combined with ANY other impairment of the digit.

Case 2 - Upper Extremity, Hand MMI/IR

- Thumb = 6% hand
- Index finger = 18% hand
- Middle finger = 14% hand
- Total hand impairment **ADD**
 - 6% + 18% + 14% = 38% hand

3rd exception to combining in the UE!

Abnormal motion					Amputation	Sensory loss	Other disorders	Hand impairment%		
Record motion, ankylosis, and impairment %					Mark level & impairment %	Mark type, level, & impairment %	List type & impairment %	• Combine digit IMP% *Convert to hand IMP%		
		Flexion	Extension	Ankylosis	IMP%					
Thumb	IP	Angle*	40	-10						
		IMP%	3%	2%			5%			
	MP	Angle*	40	0			2%			
		IMP%	2%	0%						
	CMC	Radial abduction	Angle*	35						Abnormal motion [1] 14%
			IMP%	1%				1%		Amputation [2]
Adduction		CMS	3					Sensory loss [3]		
		IMP%	3%			3%		Other disorders [4]		
Opposition	CMS	6					Digit impairment %			
	IMP%	3%			3%		• Combine 1, 2, 3, 4 14%			
Add impairment % CMC + MP + IP = 14% [1]					IMP % = [2]	IMP % = [3]	IMP % = [4]	Hand impairment %		
								*Convert above 6%		
		Flexion	Extension	Ankylosis	IMP%					
Index	DIP	Angle*								
		IMP%							Abnormal motion [1]	
	PIP	Angle*							Amputation [2] 90%	
		IMP%							Sensory loss [3]	
	MP	Angle*							Other disorders [4]	
		IMP%							Digit impairment %	
• Combine impairment % MP + PIP + DIP = [1]					IMP % = 90% [2]	IMP % = [3]	IMP % = [4]	Hand impairment %		
								*Convert above 18%		
Middle	DIP	Angle*	50	-20						
		IMP%	10%	4%			14%		Abnormal motion [1] 53%	
	PIP	Angle*	60	-10					Amputation [2]	
		IMP%	24%	3%			27%		Sensory loss [3] 40%	
	MP	Angle*	60	-10					Other disorders [4]	
		IMP%	17%	7%			24%		Digit impairment %	
• Combine impairment % MP + PIP + DIP = 53% [1]					IMP % = [2]	IMP % = 40% [3]	IMP % = [4]	Hand impairment %		
								*Convert above 14%		
Ring	DIP	Angle*								
		IMP%							Abnormal motion [1]	
	PIP	Angle*							Amputation [2]	
		IMP%							Sensory loss [3]	
	MP	Angle*							Other disorders [4]	
		IMP%							Digit impairment %	
• Combine impairment % MP + PIP + DIP = [1]					IMP % = [2]	IMP % = [3]	IMP % = [4]	Hand impairment %		
								*Convert above		

Total hand impairment (Add hand impairment % for thumb + index + middle + ring + little finger) =	38 %
Upper extremity impairment (*Convert total hand impairment % to upper extremity impairment %) =	34 % ; enter on Part 2, Line II
If hand region impairment is only impairment, convert upper extremity impairment to whole-person impairment:† =	20 %

• Combined Values Chart; (p. 322-324)

*Use Table 1 (Digits to hand p. 18);

†Use Table 2 (Hand to upper extremity p. 19)

‡Use Table 3 (p. 20)

** Courtesy of G. de Groot Swanson, MD

Convert Hand to Upper Extremity

Table 2, Page 19

Table 2. Relationship of Impairment of the Hand to Impairment of the Upper Extremity.*

% Impairment of		% Impairment of		% Impairment of		% Impairment of		% Impairment of		% Impairment of	
Hand	Upper extremity	Hand	Upper extremity	Hand	Upper extremity	Hand	Upper extremity	Hand	Upper extremity	Hand	Upper extremity
0 =	0	18 =	16	35 =	32	53 =	48	70 =	63	88 =	79
1 =	1	19 =	17	36 =	32	54 =	49	71 =	64	89 =	80
2 =	2			37 =	32			72 =	65		
3 =	3	20 =	18	38 =	34	55 =	50	73 =	66	90 =	81
4 =	4	21 =	19	39 =	35	56 =	50	74 =	67	91 =	82
5 =	5	22 =	20	40 =	36	57 =	51	75 =	68	92 =	83
6 =	5	23 =	21	41 =	37	58 =	52	76 =	68	93 =	84
7 =	6	24 =	22	42 =	38	59 =	53	77 =	69	94 =	85
8 =	7	25 =	23								
9 =	8	26 =	24								
10 =	9	27 =	25								
11 =	10	28 =	26	46 =	43	63 =	57	81 =	73	98 =	88
12 =	11	29 =	27	47 =	44	64 =	58	82 =	74	99 =	89
13 =	12							83 =	75		
14 =	13	30 =	27			65 =	59	84 =	76	100 =	90
		31 =	28			66 =	59				
15 =	14	32 =	29	50 =	45	67 =	60	85 =	77		
16 =	14	33 =	30	51 =	46	68 =	61	86 =	77		
17 =	15	34 =	31	52 =	47	69 =	62	87 =	78		

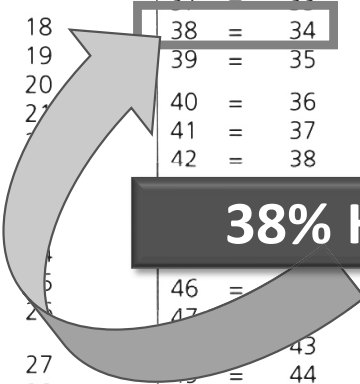

38% Hand = 34% Upper Extremity

*Consult Table 3 (p. 20) to convert upper extremity impairment to whole-person impairment.

Case 2 – Hand and Upper Extremity MMI/IR

- **38% hand = 34% UE**
- Since this is the ONLY UE impairment, convert the UE to WP, **34 % UE = 20% WP**
- *If there are other UE impairments, put the value of the hand under Section II, on Figure 1 – Part 2, so that it can be combined with the other regional impairments, PRIOR to converting to WP*

Case 2 – Hand and Upper Extremity MMI/IR – Convert to WP

Table 3. Relationship of Impairment of the Upper Extremity to Impairment of the Whole Person.

% Impairment of Upper extremity		% Impairment of Whole person		% Impairment of Upper extremity		% Impairment of Whole person		% Impairment of Upper extremity		% Impairment of Whole person	
0	=	0		35	=	21		70	=	42	
1	=	1		36	=	22		71	=	43	
2	=	1		37	=	22		72	=	43	
3	=	2		38	=	23		73	=	44	
4	=	2		39	=	23		74	=	44	
5	=	3		40	=	24		75	=	45	
6	=	4		41	=	25		76	=	46	
7	=	4		42	=	25		77	=	46	
8	=	5		43	=	26		78	=	47	
9	=	5		44	=	26		79	=	47	
10	=	6		45	=	27		80	=	48	
11	=	7		46	=	28		81	=	49	
12	=	7		47	=	28		82	=	49	
13	=	8		48	=	29		83	=	50	
14	=	8		49	=	29		84	=	50	
15	=	9		50	=	30		85	=	51	
16	=	10		51	=	31		86	=	52	
17	=	10		52	=	31		87	=	52	
18	=	11		53	=	32		88	=	53	
19	=	11		54	=	32		89	=	53	
20	=	12		55	=	33		90	=	54	
21	=	13		56	=	34		91	=	55	
22	=	13		57	=	34		92	=	55	
23	=	14		58	=	35		93	=	56	
24	=	14		59	=	35		94	=	56	
25	=	15		60	=	36		95	=	57	
26	=	15		61	=	37		96	=	58	
27	=	16		62	=	37		97	=	58	
28	=	17		63	=	38		98	=	59	
29	=	17		64	=	38		99	=	59	
30	=	18		65	=	39		100	=	60	
31	=	19		66	=	40					
32	=	19		67	=	40					
33	=	20		68	=	41					
34	=	20		69	=	41					

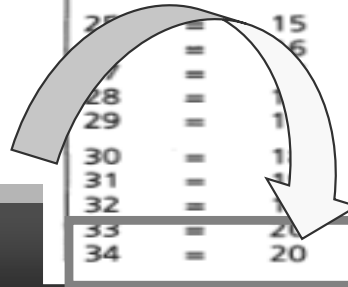

Case 2 – Hand and Upper Extremity MMI/IR

WHAT ARE THE CONCEPTS to take away from Case 2?

- Know the 4 exceptions to combining, in other words **WHEN to ADD values for the hand.**
 1. ADD ROM losses WITHIN a joint
 2. ADD ROM losses joint TO joint for the thumb ONLY
 3. ADD digit impairments that have been taken to the HAND value
 4. ADD longitudinal sensory loss , IF the radial and ulnar side of the SAME digit are affected.

Case 2 – Hand and Upper Extremity MMI/IR

WHAT ARE THE CONCEPTS to take away from Case 2?

- Difference in approaching TOTAL TRANSVERSE vs. LONGITUDINAL loss.
- Know the difference between PARTIAL vs TOTAL loss of sensation of the digit
- May COMBINE ROM / sensory loss / amputation with OTHER disorders in same DIGIT, at the level of the digit.

**Any Questions
about Case 2 –
UE MMI/IR?**



Case 3 – Upper Extremity MMI/IR

- 25-year-old male waiter tripped and fell at work landing on outstretched left arm
- Sustained fracture of left distal radius
- Underwent open reduction and internal fixation (ORIF) with plating by orthopedist
- Fracture healed
- 12 visits of post-op PT with increased ROM and strength

Case 3 - Upper Extremity MMI/IR

- Subsequently complained of pain and loss of sensation in left hand.
- Electrodiagnostic studies consistent with severe sensorimotor median neuropathy
- Underwent nerve decompression 12 months post injury
- Reached clinical plateau with no reasonable anticipation of further material recovery or lasting improvement
- Saw Designated Doctor for MMI and IR

Case 3 - Upper Extremity MMI/IR

DD Medical History

- Loss of sensation left thumb and index finger which interferes but does not prevent sleep, playing guitar and other ADLs
- RTW as waiter



Case 3 - Upper Extremity MMI/IR

DD Physical Exam

- Well healed surgical scar left wrist
- ROM left wrist
 - Flexion 24°
 - Extension 15°
 - Radial deviation 5°
 - Ulnar deviation 14°
- ROM left forearm
 - Pronation 25°
 - Supination 45°

Case 3 - Upper Extremity MMI/IR

DD Physical Exam (cont'd)

- 5/5 strength of fingers, wrist and forearm muscles bilaterally
- 12 mm 2-point discrimination of palmar surface of radial and ulnar portions of left thumb and radial and ulnar side of index finger
- 6 mm 2-point discrimination over all other parts of left hand

Case 3 – Upper Extremity MMI/IR

Based on medical records and physical exam, what is the compensable injury for certifying MMI and IR?

130.1(c)(3)



Case - Upper Extremity MMI/IR

What is compensable injury for certifying MMI and IR?

- A. Left distal radius fracture
- B. Traumatic median neuropathy
- C. A and B
- D. Any others?



Case 3 – Upper Extremity MMI/IR

Question for DD to
consider in the exam:

On MMI date what is
whole person IR?

Show your work!



Case 3 – Upper Extremity MMI/IR

**On date of MMI, what is
whole person IR?**

- A. 35%
- B. 22%
- C. 21%
- D. 15%



Case 3 - Upper Extremity MMI/IR

What are you rating?

- **Fracture resulting in wrist and forearm ROM loss**
- **Median Nerve Injury**
 - RATE the LEVEL of the LESION!
 - The sensory loss is at the level of the median nerve
NOT the digital nerves

Wrist Range of Motion

- Determine impairment values-based Figure 26, page 36 and Figure 29, page 38
- **Round ROM to nearest 10° per written instructions for UD and RD, rather than 5° increments in Figure 29**
 - Appeals Panel decision 022504-s
- **Add different motion impairments of wrist**
- **Use Figure 1, Part 2 – combine** with other UE impairments and convert to whole person using Table 3

Wrist Flexion / Extension

Figure 26, page 36

- Flexion 24° rounds to 20° = 7% UE
- Extension 15° rounds to 20° = 7% UE
- F + E = 14% UE

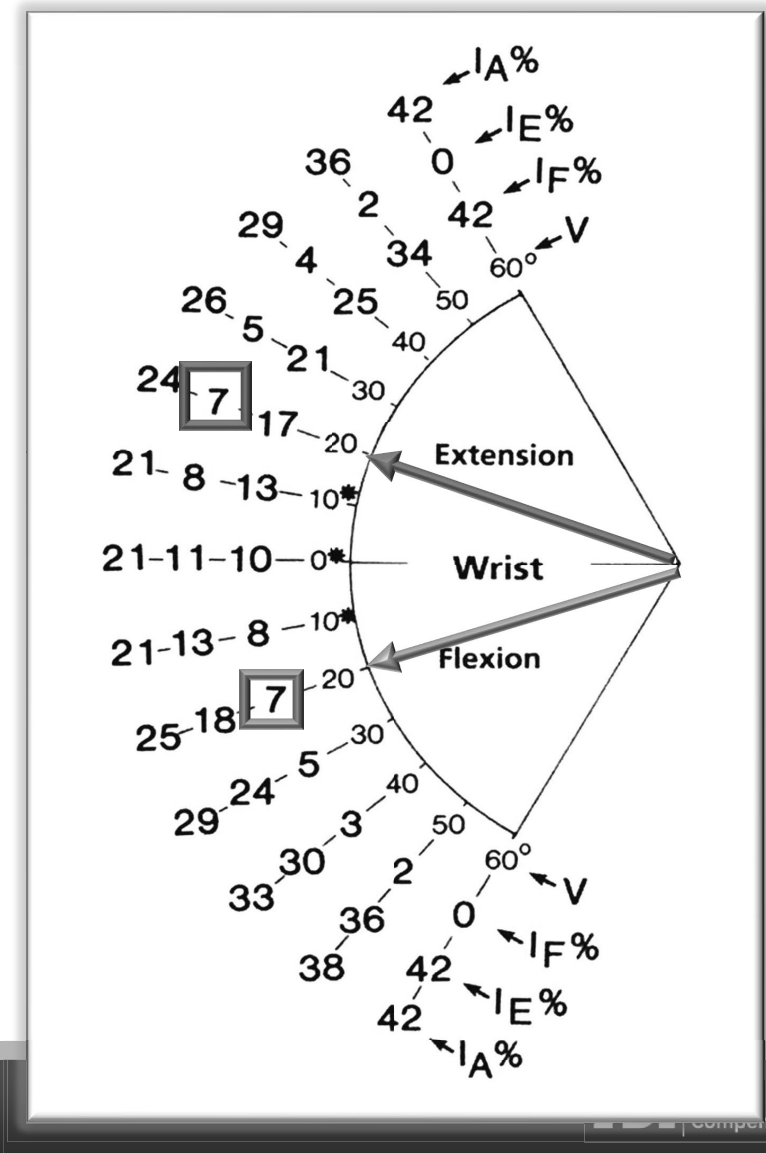

Wrist Flexion / Extension

Figure 29, page 38

- Radial deviation 5° rounds to 10° = 2% UE
- Ulnar deviation 14° rounds to 10° = 4% UE
- RD + UD = 6% UE

ADD F/E + RD/UD

- 14% UE + 6% UE = 20% UE

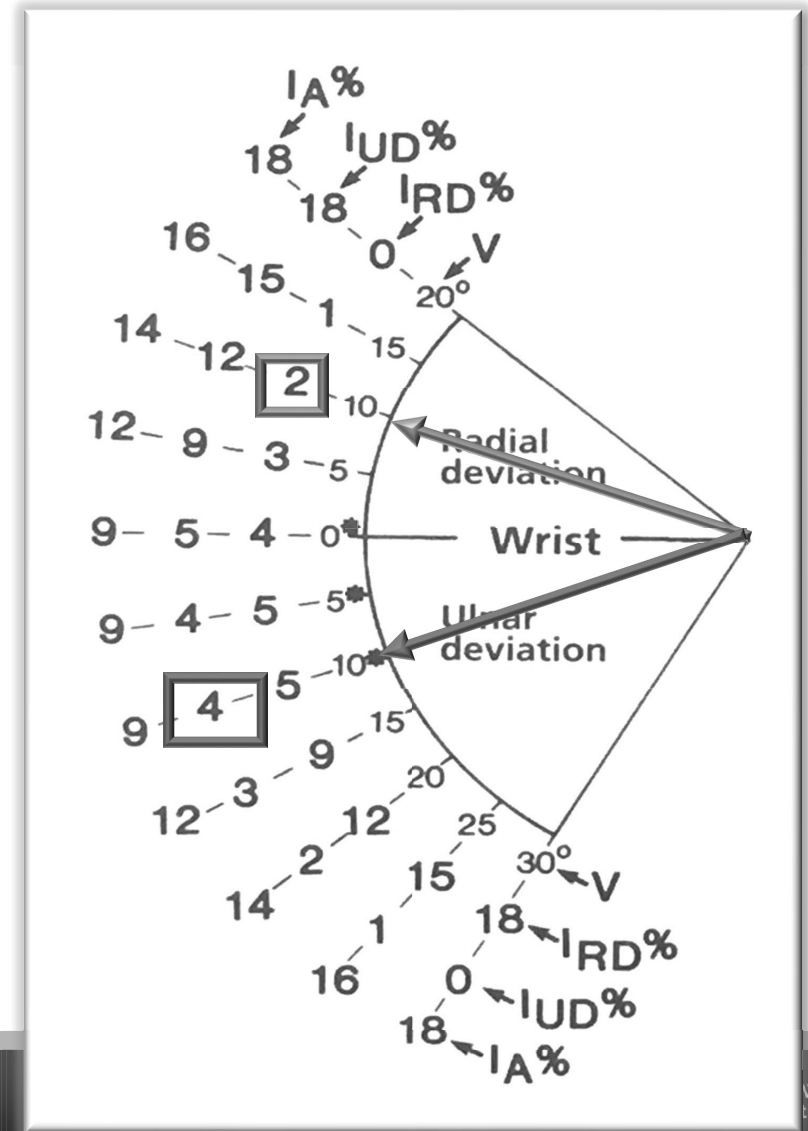

What About Supination and Pronation for Wrist Injuries?

- While pronation and supination is discussed under elbow/forearm ROM, these are also a function of the wrist.
- See example of Colles fracture on page 72

Elbow/Forearm Pronation and Supination

Supination 45° rounds
to 50° = 1% UE

Pronation 25° rounds
to 30° = 3% UE

**3% UE + 1% UE = 4%
UE**

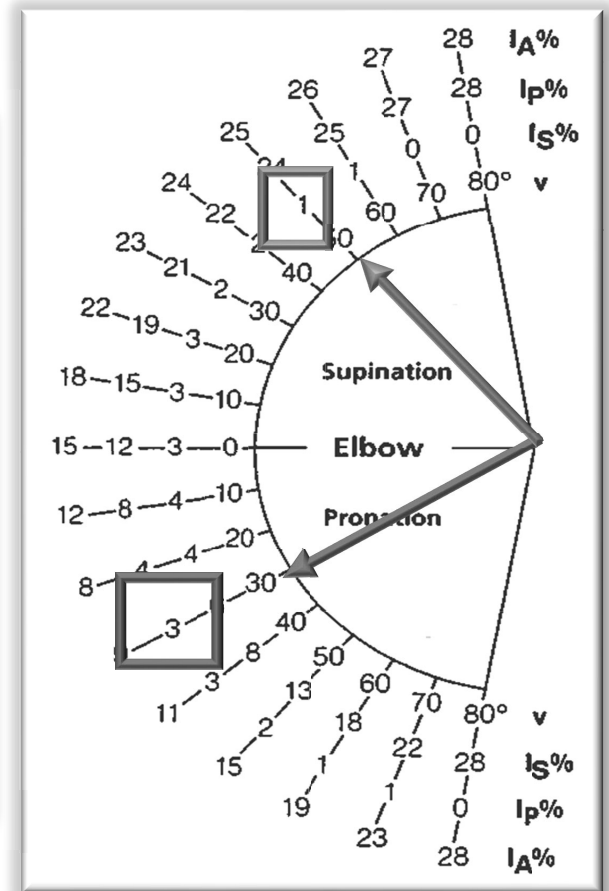
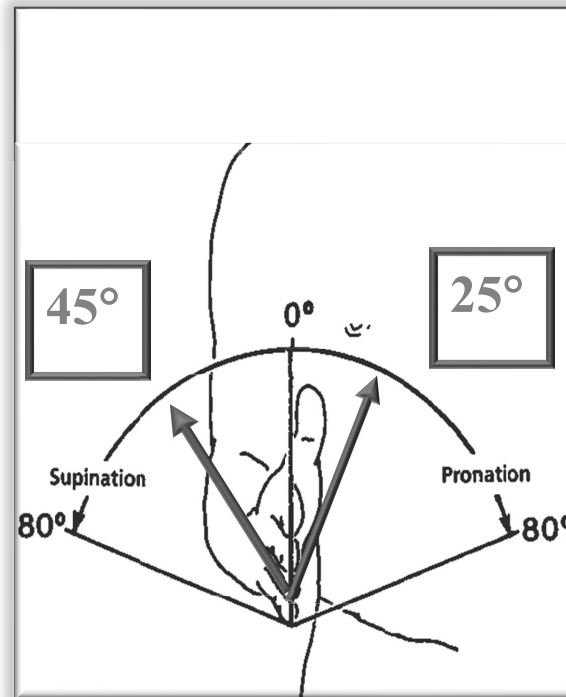

3.1m - Entrapment Neuropathy

Table 16, Page 57

- Alternative method for rating nerve lesions as a result of entrapment neuropathy (not traumatic nerve injury)
- **No definitions of mild, moderate, or severe**
- Can be problematic given lack of criteria for selecting severity degree category
- If used, must sufficiently explain reason for selecting severity degree category
- ***Show your work!***

Peripheral Nerve Disorders

(i.e., Carpal Tunnel Syndrome)

- Peripheral nerve disorders such as the entrapment neuropathy (like carpal tunnel syndrome) should be evaluated by the tables for sensory and motor nerve loss
- **BEST PRACTICE -**
 - DO NOT use Table 16, page 57
 - DO NOT use ROM for peripheral nerve disorders unless there is a separate MSK lesion

Peripheral Nerve Disorders (*i.e., Carpal Tunnel Syndrome*)

While there can be electrodiagnostic (EMG / NCS) parameters for MILD, MODERATE, SEVERE, testing results are:

- Not always synonymous with the clinical condition,
- Usually from the past, pre-treatment and not reflecting the condition at MMI
- Usually only 1 – 2 max of the affected digits are tested

Case 3 – Anatomic Distribution of Median Nerve Sensory Loss

Loss of sensation of palmar surface of radial and ulnar portions of left thumb and radial and ulnar sides of index finger

- 4 of the potential 7 sides of digits that can be affected by median nerve lesions

Peripheral Nerve Disorders

Table 15, Page 54



7% + 11% + 5% + 4% = 27% UE MAX VALUE

Nerve	Maximum % upper extremity impairment*		
	Due to sensory deficit or pain †	Due to motor deficit ‡	Due to combined motor and sensory deficits
Pectorals (medial and lateral)	0	5	5
Axillary	5	35	38
Dorsal scapular	0	5	5
Long thoracic	0	15	15
Medial antebrachial cutaneous	5	0	5
Medial brachial cutaneous	5	0	5
Median (above midforearm)	38	44	65
Median (anterior interosseous branch)	0	15	15
Median (below midforearm)	38	10	44
Radial palmar digital of thumb	7	0	7
Ulnar palmar digital of thumb	11	0	11
Radial palmar digital of index finger	5	0	5
Ulnar palmar digital of index finger	4	0	4
Radial palmar digital of middle finger	5	0	5
Ulnar palmar digital of middle finger	4	0	4
Radial palmar digital of ring finger	2	0	2
Musculocutaneous	5	25	29
Radial (upper arm with loss of triceps)	5	42	45
Radial (elbow with sparing of triceps)	5	35	38
Radial (upper arm with loss of triceps)	5	16	20
Radial (elbow with sparing of triceps)	10	10	10
Ulnar (above midforearm)	7	46	50
Ulnar (below midforearm)	7	35	40
Ulnar palmar digital of ring finger	2	0	2
Radial palmar digital of little finger	2	0	2
Ulnar palmar digital of little finger	3	0	3

Case 3 - Sensory Loss of Median Nerve

Loss of sensation left thumb and index finger which interferes but does not prevent sleep, playing guitar and other ADLs

Peripheral Nerve Disorders

Table 11, Page 48

a. Classification		
Grade	Description of sensory deficit or pain	% Sensory deficit
1	No loss of sensibility, abnormal sensation, or pain	0
2	Decreased sensibility with or without abnormal sensation or pain, which is forgotten during activity	1 - 25
3	Decreased sensibility with or without abnormal sensation or pain, which interferes with activity	26 - 60
4	Decreased sensibility with or without abnormal sensation or pain, which may interfere with activity, and/or minor causalgia	61 - 80
5	Decreased sensibility with abnormal sensations and severe pain, which prevents activity, and/or major causalgia	81 - 100



27% UE x .60 = 16% UE

Instructions From Page 48

Example: After an injury to his elbow, a man continued to have pain and abnormal sensations (minor causalgia) in the medial aspect of his right forearm that prevented activity.

1. Area of involvement is the medial aspect of right forearm (Fig. 45, p. 50).
2. Nerve involved is the medial antebrachial cutaneous (Table 10, p. 47).
3. Maximum loss of function due to sensory deficit is 5% (Table 15, p. 54).
4. Grade of sensory deficit or pain is 61% to 80% (Table 11a right) **use maximum value.**
5. Impairment of the upper extremity is calculated to be 80% x 5%, or 4%. This is equivalent to a 2% whole-person impairment (Table 3, p. 20).

Case 3 - Upper Extremity MMI/IR

- Wrist ROM = 20% UE
- Elbow/forearm ROM = 4% UE
- Median nerve sensory loss = 16% UE
- **Combine**
 - 20% UE cw 4% UE = 23% UE regional impairments (wrist and elbow/forearm)
 - 23% UE cw 16% UE = 35% UE *then* peripheral nerve
 - 35% UE  21% WP (Table 3, page 20)

35% UE = 21% Whole Person

Convert Upper
Extremity to Whole
Person

Table 3, Page 20

% Impairment of		% Impairment of		% Impairment of	
Upper extremity	Whole person	Upper extremity	Whole person	Upper extremity	Whole person
0	= 0	35	= 21	70	= 42
1	= 1	36	= 22	71	= 43
2	= 2	37	= 22	72	= 43
3	= 3	38	= 23	73	= 44
4	= 4	39	= 23	74	= 44
	= 5			75	= 45
6	= 6	40	= 24	76	= 46
7	= 7	41	= 25	77	= 46
8	= 8	42	= 25	78	= 47
9	= 9	43	= 26	79	= 47
	= 10			80	= 48
10	= 11	44	= 26	81	= 49
11	= 12	45	= 27	82	= 49
12	= 13	46	= 28	83	= 50
13	= 14	47	= 28	84	= 50
14	= 15	48	= 29	85	= 51
	= 16			86	= 52
15	= 17	49	= 29	87	= 52
16	= 18	50	= 30	88	= 53
17	= 19	51	= 31	89	= 53
18	= 20	52	= 31	90	= 54
19	= 21	53	= 32	91	= 55
	= 22			92	= 55
20	= 23	54	= 32	93	= 56
21	= 24	55	= 33	94	= 56
22	= 25	56	= 34	95	= 57
23	= 26	57	= 34	96	= 58
24	= 27	58	= 35	97	= 58
	= 28			98	= 59
25	= 29	59	= 35	99	= 59
26	= 30	60	= 36	100	= 60
27	= 31	61	= 37		
28	= 32	62	= 37		
29	= 33	63	= 38		
	= 34				
30	= 35	64	= 38		
31	= 36	65	= 39		
32	= 37	66	= 40		
	= 38				
	= 39	67	= 40		

Figure 1. Upper Extremity Impairment Evaluation Record—Part 2 (Wrist, elbow, and shoulder) Side R L

Name Lief A Bigtip Age 24 Sex M F Dominant hand R L Date mm/dd/yy
 Occupation Waiter Diagnosis left distal radius & ulnar fractures, carpal tunnel syndrome

Abnormal motion					Other disorders	Regional impairment %	Amputation	
Record motion, ankylosis and impairment %					List type & impairment %	• Combine [1] + [2]	Mark level & impairment %	
Wrist	Flexion	Extension	Ankylosis	IMP%				
	Angle°	20	20					14
	IMP%	7	7					
	RD	UD	Ankylosis	IMP%				
	Angle°	10	10					6
	IMP%	2	4					
Add IMP% F/E + RD/UD = 20%					[1]	IMP% = [2]		
Elbow	Flexion	Extension	Ankylosis	IMP%				
	Angle°							
	IMP%							
	Pro	Sup						
	Angle°	30	50					
	IMP%	3	1					
Add IMP% F/E + PRO/SUP = 4%								

Figure 1, Part 2...

Convert Upper Extremity IR to Whole person IR

II. Regional impairment of upper extremity • (Combine hand _____% + wrist <u>20</u> % + elbow <u>4</u> % + shoulder _____%)	=	<u>23%</u>
III. Peripheral nerve system impairment <u>27% UE x 60%</u>	=	<u>16%</u>
Total upper extremity impairment (• Combine I + II + III + IV + V)	=	<u>35%</u>
Impairment of the whole person (Use Table 3 p. 20)	=	<u>21%</u>

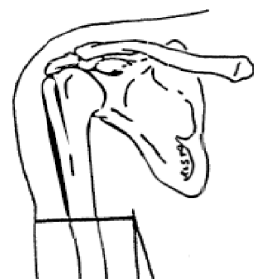

Other Issues

- Would you rate wrist ROM for CTS?
- What about grip strength?

Upper Extremity – Grip Strength

Strength Evaluation - 3.1 m (Pages 64-65)

- Rarely used, subject to patient effort
- Not specific to any given nerve
- If used, describe why this was a “rare case”
 - page 64

Upper Extremity – Grip Strength

Strength Evaluation - 3.1 m (Pages 64-65) (cont'd)

- **Must determine maximal, valid effort**
 - document findings in your report
 - 3 measurements each hand < 20% variation
 - 5 position grip – bell shaped curve
 - Rapid exchange grip
- **Do not double rate with strength loss from nerve injury**
- Use Tables and formulas on pages 64-65 to determine loss

**Any Questions about
Case 3 - UE MMI/IR?**



RSD/CRPS

RSD / CRPS should be diagnosed AND verified by HARDIN AND BUDAPEST criteria.

- Rate ROM loss
 - must be maximal and reproducible/consistent
- Rate sensory deficit/pain from Table 11, page 48
- Rate motor deficit of injured peripheral nerve, if it applies (i.e. CRPS II) from Table 12, page 49
- Combine sensory deficit/pain and motor deficit
- Combine ROM with value from sensory deficit/pain and motor deficit

RSD / CRPS

- If there is evidence of stiffness (due to edema in the acute phase or end stage dystrophic CRPS), then ROM of the affected area should also be measured and all combined
- If ROM is limited due to **pain inhibition**, and loss is inconsistent with degree of edema, or atrophy or other dystrophic changes, then that would already be accounted for in descriptors of higher grades of sensory loss on Table 11 (UE)

[Example: Grade 4 = “*which may prevent activity, and / or causalgia*”]

Any Questions About Upper Extremity MMI/IR?



Upper Extremity Pearls follow next, but Don't forget...

- Please submit your evaluation for the Upper Extremity MMI/IR presentation.

<https://www.tdi.texas.gov/wc/dd/training.html>

- Please submit your attestation form for the pre-recorded presentations.

<https://forms.office.com/g/FWFsTxiwtY>

UPPER EXTREMITY PEARLS

This review section will not necessarily be covered in the Certification Course.

This section is to enhance your study for testing or improve your DD opinions.

It is important that you go to your AMA GUIDES TO PERMANENT IMPAIRMENT, 4th Edition and highlight, make notes etc.

The point is to have you learn the concepts and NOT memorize information

MOST IMPORTANT
"REQUIREMENT"
FOR UPPER EXTREMITY
IMPAIRMENT EVALUATION:

Use Figure 1, Part 1 - pp. 16

Use Figure 1, Part 2 - pp. 17

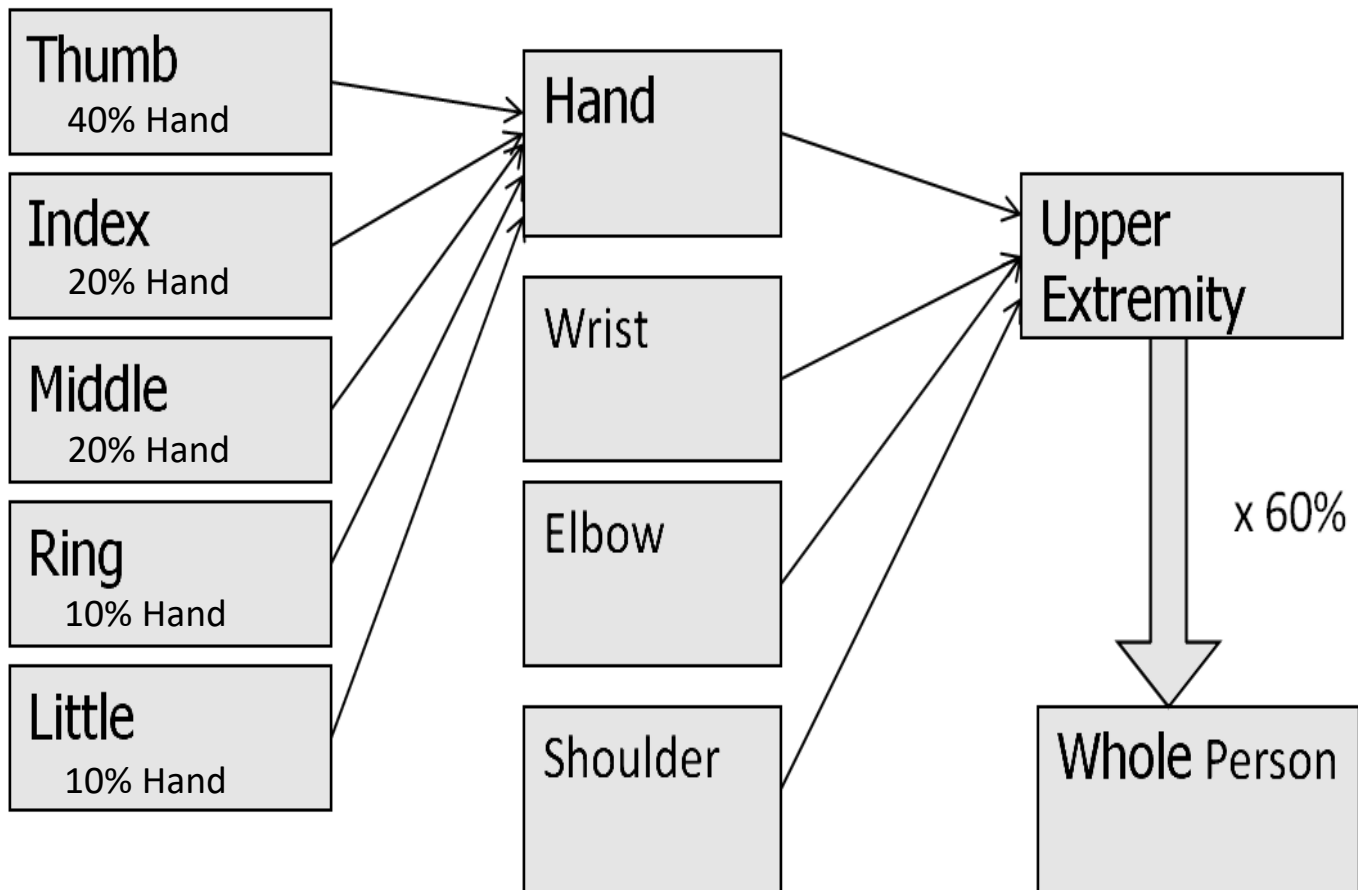

How to Determine Impairment Rating Hand and Upper Extremity

- No rating for hand/upper extremity dominance.
- No specific requirement (or prohibition) to measure the uninvolved contralateral upper extremity in the 4th Ed. of *Guides* (as per 3rd, 5th and 6th Editions).

How to Determine Impairment Rating Hand and Upper Extremity

AMA Guides 4th Edition: Chapter 3, page 14

"Evaluating the range of motion of an extremity or the spine is a valid method of estimating an impairment. To some extent, however, the ROM is subject to the patient's control".

"The results of such evaluations should be consistent and concordant with the presence or absence of pathologic signs or other evidence."

How to Determine Impairment Rating Hand and Upper Extremity

- **Active**, not passive range of motion (ROM) should be measured/rated; p. 15
- **Round UE ROM to nearest 10 degrees** per **written instructions** *AMA Guides* 4th ed., pp. 25-44 ; also p. 15 (NOT 5-degree increments per Figure 29, p. 38 wrist RD/UD)
- Appeals Panel decision 022504-s, decided November 12, 2002

How to Determine Impairment Rating Hand and Upper Extremity

- UE ROM - Guides, 4th do not directly address rounding 5 degrees; however generally recommended that <5 degrees round down, ≥ 5 degrees round up
- Do not round the WHOLE PERSON impairment rating in DWC system as instructed in *AMA Guides* (p. 9)

Rounding negative ROM degrees (extension lag/flexion contracture)

Section 3.1d Evaluating Abnormal Motion (p. 22)

“...a finger joint flexion contracture of 15° with flexion to 45° would be recorded as -15° to 45°. The motion of a finger joint that has 15° of hyperextension and 45° of flexion would be recorded as +15° to 45° (figure 6, p. 23).

The plus and minus signs are used to indicate, respectively, hyper-extension and extension lag and have no mathematical significance.”

Rounding negative ROM degrees (extension lag/flexion contracture) - continued

- Since there is no mathematical significance to the plus or minus symbols of ROM degrees, all degrees can be rounded using the same **best practice** method:
- Round upper extremity ROM measurement degrees to the nearest 10°
 - Rounding down when the number ends in 4 or less,
 - Rounding up when the number ends in 5 or greater.

Rounding negative ROM degrees (extension lag/flexion contracture) - continued

- **Remember - rounding to the nearest 10° DOES NOT apply to the lower extremity.**
- For the lower extremity use the absolute measurement to determine the IR, including to stratify into a category
- Example: Table 41 for the knee grades extension lag as
 - Mild (5 (-5 to -9 degrees)
 - Moderate (-10 to -19 degrees)
 - Severe (-20 +).

How to Determine Impairment Rating Hand and Upper Extremity

- ROM
- Sensory loss of digits (Various Figures / Tables)
- ROM (Various Figures)
- Peripheral nerve disorders
 - Cervical Spinal Nerve Roots (Table 13)
 - Brachial Plexus (Table 14)
 - Major Peripheral Nerves (Table 15)
- Vascular Disorders
- "Other Disorders"

How to Determine Impairment Rating Hand and Upper Extremity

- COMBINE different TYPES or SYSTEMS of Impairment
- Musculoskeletal / Nerve / Vascular)
- AVOID “double impairing” ROM loss IF the ROM loss is due to a nerve injury

How to Determine Impairment Rating Hand and Upper Extremity

ROM:

- Most values are recorded in degrees of motion as measured with a goniometer with a corresponding pie chart
- Thumb adduction, opposition, and radial abduction are the exceptions (Figures 9, 12, 14, and 16 on pp 26-29)

Abnormal Motion of the Digits

THUMB ROM:

Five Areas of Motion

- **ADD** impairment losses of *different* joints of thumb

NON-THUMB DIGITS (3 joints)

- **COMBINE** impairment losses of *different* joints of the Non-thumb digits
- Convert using Tables 1, 2, and 3 (use Fig. 1!)

What do you do with multiple types of impairments of a digit ?

- Determine impairment from each TYPE of impairment
 - range of motion,
 - sensory,
 - amputation,
 - other disorders (lateral deviation and rotational deformities)
- **COMBINE** the different TYPES to arrive at a ***total impairment*** for that ***digit***.

Sensory Loss of the Digits

RATE THE LEVEL OF THE LESION!

Section 3.1c (p. 20 – 22, 24 – 31)

Sensory loss:

- **Must be unequivocal and permanent** (p. 20)
- Not an impairment of the dorsal surface

Impairments are estimated according to the sensory quality and its distribution on the **PALMAR** aspect of the digits. Sensory loss on the DORSAL surface of the digits is NOT considered to be an impairment." (p.20)

Sensory Loss of the Digits

QUALITY of LOSS, p. 21

- Determine by **two-point exam**
- > 15 mm = **total** sensory loss, 100% sensory impairment
- 15 mm through 7 mm – **partial** sensory loss, 50% sensory impairment
- ≤ 6 mm is **normal**, 0% sensory impairment

Sensory Loss of the Digits

RATE THE LEVEL and TYPE OF THE LESION!

Transverse Loss

- a) Loss of function in **both digital nerves in a digit at the SAME level and quality**
- b) 100% sensory loss and receives 50% value of the amputation value at that level
- c) Thumb – Figure 7, p. 24
- d) Fingers – Figure 17, p. 30

Sensory Loss of the Digits

RATE THE **LEVEL** and **TYPE** OF THE LESION!

Longitudinal Loss

- a) **One** Digital Nerve
- b) Impairment value varies as to side injured (radial vs. ulnar side of digit)
- c) Be sure to read sections on proper use of Tables
- d) Thumb/little – T. 4, p. 25 and T. 8, p. 31
- e) IF impairment at different level / degree of radial and ulnar side, rate each side and ADD for the sensory loss of the digit.

Amputation

Loss of entire UE – 60% WP

Rate DIGIT amputation:

- Per Figure 7 (thumb)
- Per Figure 17 (finger), Figure 3
- Per Figure 3 (impairments of the digits and hand)
- Per Figure 2 (impairments of the UE)

- **Use Figure 1 – Part 1 and Part 2**

If digits – COMBINE with other digit impairments

If digit – Convert digit to hand using T. 1, p. 18 AND convert hand to UE using T. 2, p. 19

Convert UE to WP if no other UE ratings using T. 3, p. 20

What if more than one digit has an impairment?

1. Determine the impairment of ***each individual digit***.
2. **Convert** each digit impairment to a **hand** impairment using Table 1.
3. **Add** each digit (I-V) impairment at the level of the hand for a ***total hand impairment***
4. Convert hand to UE using Table 2
5. Convert UE to whole person using Table 3

Peripheral Nerve Disorders

RATE THE LEVEL OF THE LESION! (Tables 13 / 14/ 15)

Section 3.1k (p. 46)

Cervical Spinal Roots (Table 13)

*If you determine that there is a specific spinal nerve root injury / deficit, that is NOT rate-able per the SPINE section (i.e. nerve root avulsion)

Brachial Plexus (Table 14)

*If you determine that there is a brachial plexus injury / deficit.

Major Peripheral Nerves (Table 15)

*If you determine that there is a specific Major Peripheral nerve (cutaneous, pure motor or mixed.)

Peripheral Nerve Disorders

RATE THE LEVEL OF THE LESION!

(for Tables 13 / 14/ 15)

Section 3.1k – Table 11 – PAIN / SENSORY deficits (p. 48)

- How does deficit interfere with ADL that is present at MMI?
- Does it follow a defined, specific anatomic distribution? (nerve root, plexus, peripheral nerve)
- Is the injury/condition consistent with a peripheral nerve disorder?

Peripheral Nerve Disorders

RATE THE LEVEL OF THE LESION! (Tables 13 / 14/ 15)

Section 3.1k – Table 12 – MOTOR deficits (p. 49)

- Is there a loss of strength, or specific muscle loss of function, that is present and reproducible on the clinical exam?
- Is this consistent with the injury, clinical condition and prior medical records?
- Is the strength loss in a defined, specific anatomic pathway of the injured nerve? (nerve root, plexus, peripheral nerve)

Peripheral Nerve Disorders

Section 3.1k – Table 12 – Motor deficits (p. 49)

Use instead of, and do not combine with, Section 3.1m methods:

- Loss of strength section 3.1m (Impairment due to other disorders of the UE). [Rarely used]
- Entrapment Neuropathy – Table 16 (p. 57)
- Grip Strength Loss – Tables 31 – 34 (p. 64-65)

Peripheral Nerve Disorders

RATE THE LEVEL OF THE LESION! (Tables 13 / 14/ 15)

*Estimate the sensory deficit/pain from Table 11, p. 48

*Estimate the motor deficit from Table 12, P. 49.

Multiply the severity of the sensory or motor deficit by the appropriate MAXIMAL VALUE from Table 13 (p. 51), Table 14 (p. 52) or Table 15 (p. 54).

*COMBINE the sensory and motor deficits to give an UE IR value.

Use Figure 1 – Part 2 – COMBINE with other UE impairments.

*Convert to Whole Person using T. 3, p. 20.

Peripheral Nerve Disorders

- Restricted UE ROM strictly **due to** peripheral nerve lesion should **NOT** be rated with ROM method - p. 46.
- If restricted ROM is **not** strictly due to peripheral nerve disorder and there is a SEPARATE MSK condition, then ROM can be combined with peripheral nerve disorder impairment. (p. 84). EXPLAIN!
- Rate pain/sensory deficits and/or motor deficits.

Causalgia/RSD

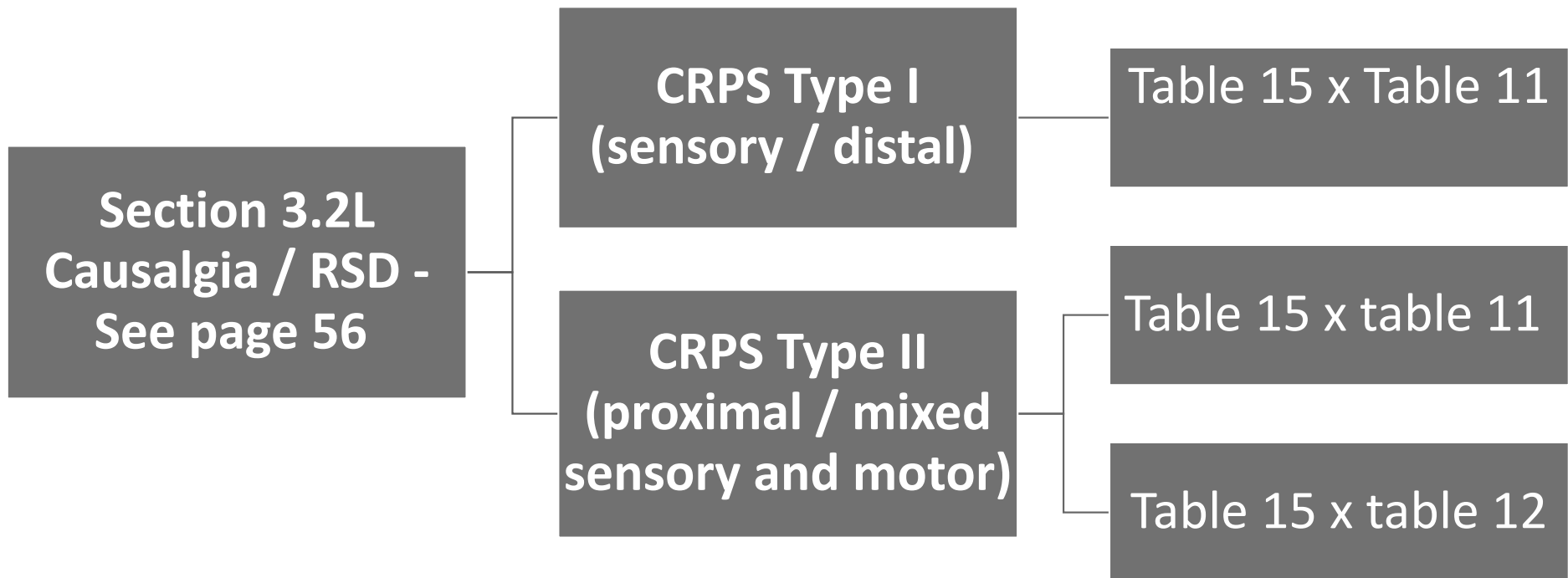

Carpal Tunnel Syndrome

- Carpal tunnel syndrome and other major peripheral nerve disorders should be evaluated by sensory and motor nerve loss, as per Table 15 x Table 11 & 12
 - Don't use ROM
 - **Best Practice** don't use T. 16, P. 57 - no definitions of mild, moderate, or severe.

Entrapment Neuropathy

T. 16, P. 57

- WHY NOT use this alternative method for rating entrapment neuropathy
- **No definitions of mild, moderate, or severe**
- Can be problematic given lack of criteria for selecting the severity degree category
- If used, explain your reason for selecting the severity degree category

SHOW YOUR WORK!

Vascular Disorders

- Section 3.1 L
- Use T. 17, p. 57
- Difficult to find exact situation with every patient
- Combine vascular rating with amputation when amputation is due to peripheral vascular disease, T. 17, p. 57

UPPER EXTREMITY Other Disorders

- Section 3.1m (p. 58)
- Impairments are under two different classes of disorders:
 - I. Bone and Joint Deformities, p. 58
 - II. Musculotendinous Impairments, p. 63

READ requirements and examples closely

Impairment Due to Other Disorders of the Upper Extremity

I. Bone & Joint Deformities

- A. Joint Crepitation with Motion
- B. Joint Swelling due to synovial hypertrophy
- C. Digit Lateral Deviation
- D. Digit rotational deformity

Impairment Due to Other Disorders of the Upper Extremity

- I. Bone & Joint Deformities (continued...)
 - E. Persistent joint subluxation or dislocation
 - F. Joint instability
 - G. Wrist and elbow joint radial and ulnar deviation
 - H. Carpal instability
 - I. Arthroplasty

Impairment Due to Other Disorders of the Upper Extremity

II. Musculotendinous Impairments

- A. Intrinsic Tightness
- B. Constrictive Tenosynovitis
- C. Extensor Tendon Subluxation at the MP Joint

Hand and Upper Extremity Pearls

More than one Upper Extremity

- Determine whole person impairment from each upper extremity
- Combine whole person impairment from each upper extremity to give total whole person impairment
 - Appeals Panel Decision 061569-s

Hand and Upper Extremity Pearls

WHEN TO ADD:

- ADD ROM losses within a joint of any upper extremity joint
- ADD ALL ROMS within a joint AND joint to joint in the thumb
- ADD longitudinal sensory loss of the digit on the radial AND ulnar side of a single digit
- Convert each involved digit to hand and ADD each HAND impairment to achieve the total impairment of the hand.

Thank you