

TDI

Safety @ Work
Division of Workers' Compensation

Cranes and Derricks in Construction

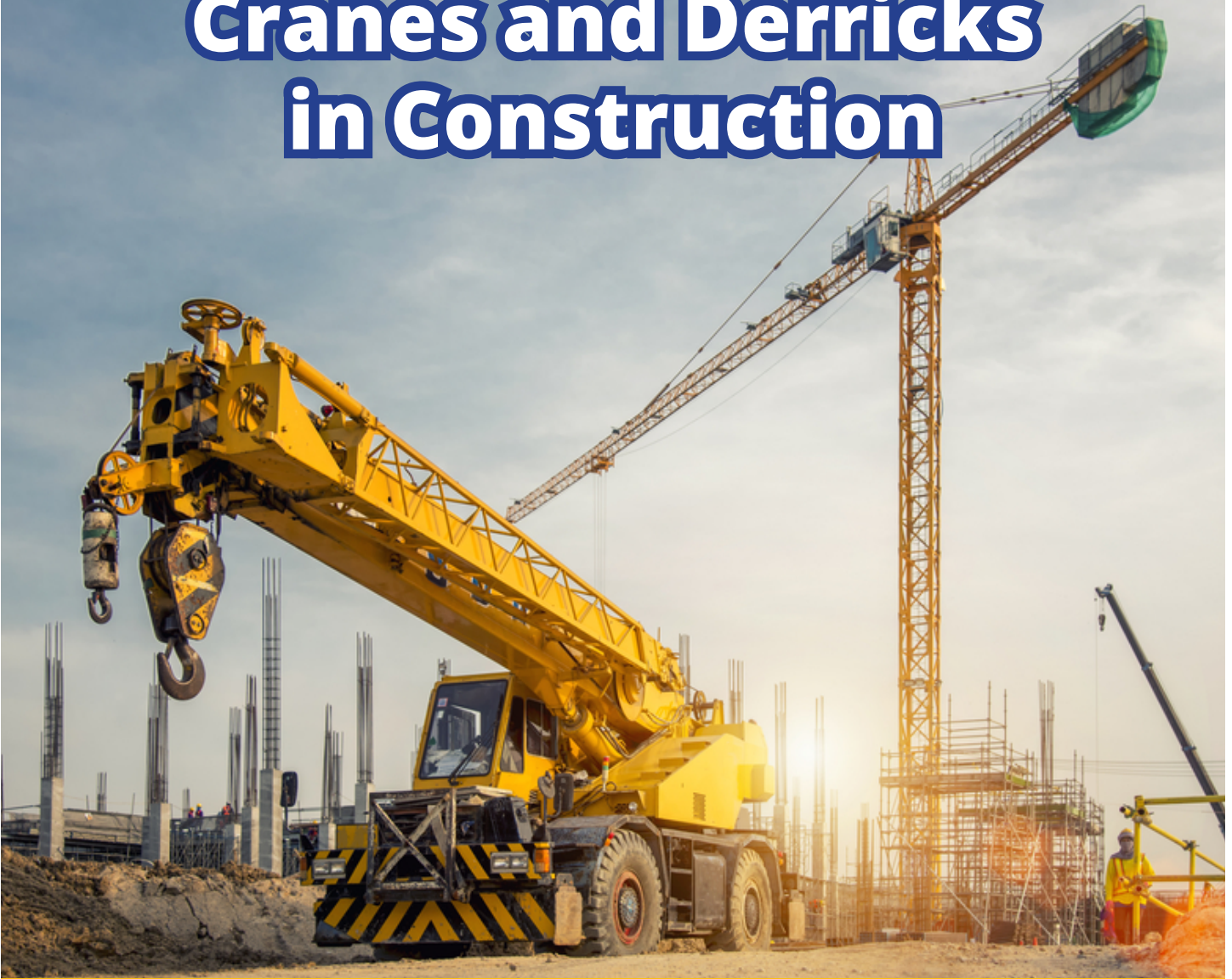

**Workplace
Program**



DISCLAIMER

This Workplace Program is a guide to help employers develop a safety plan to comply with the requirements of the Occupational Safety and Health Administration (OSHA). It contains helpful information and the basic elements to build a safety and health program when using cranes and derricks in construction. It is not meant to supersede OSHA requirements. Employers should review the OSHA standards for each specific worksite and customize the program accordingly. This Workplace Program is provided as a public service by the Texas Department of Insurance,

Division of Workers' Compensation (DWC)-Workplace Safety and the Texas Occupational Safety and Health Consultation (OSHCON) Program. The information in this document was produced, unless otherwise noted, from staff subject specialists, government entities, or other authoritative sources. Information contained in this publication is considered accurate at the time of publication. For more free DWC publications on this and other safety topics and for free occupational safety and health streaming videos, visit www.txafetyatwork.com, call 1-800-252- 7031, option 2, or email resourcecenter@tdi.texas.gov.

INTRODUCTION



There are certain machines and equipment that stand above the others, quite literally, doing the heavy industrial work that keeps our economy moving. Cranes and derricks lift heavy loads, ensuring the smooth operation of businesses worldwide. However, these powerhouses of industry come with risks and hazards that cannot be ignored.

This publication aims to provide the basic elements needed to create a safe operational environment when working with cranes and

derricks in the construction industry. However, it is not meant to replace or alter Occupational Safety and Health Administration (OSHA) requirements. Employers should review the OSHA standards specific to their worksite and customize a workplace safety program accordingly.

The following information is intended to help employers and employees build a foundation of knowledge and awareness that will safeguard lives and pave the way for a safe and healthful business.

TABLE OF CONTENTS

Cranes and Derricks in Construction Workplace Program

INTRODUCTION	3
REGULATORY COMPLIANCE	6
OSHA standards that apply	6
New changes to safety standards	6
Employer responsibilities	6
Covered and excluded equipment	7
General requirements	9
Definitions	10
CRANE & DERRICK TYPES, COMPONENTS, & SET-UP	12
Types of cranes	12
Types of derricks	14
Basic components of cranes and derricks	16
IMPORTANCE OF GROUND CONDITIONS	18
Responsibility of the controlling entity	18
Responsibility of the company operating the crane	18
ASSEMBLY & DISASSEMBLY GENERAL REQUIREMENTS	19
Required procedures	19
Responsibility of the A/D Director	19
Responsibility of the crew	20
Responsibility of the rigger	20
Avoid working under the boom	20
Protect synthetic slings	20
Use outriggers and stabilizers	21
Prevent movement when dismantling booms and jibs	21
Use fall protection	21
REQUIREMENTS WHEN WORKING NEAR POWER LINES	22
High voltage electrical clearances	23
USE ONLY TRAINED & QUALIFIED PERSONNEL	24
Qualified operator	24
Qualified rigger	25
Qualified signal person	26

LIFTING & MOVING LOADS	27
Review manufacturers' manuals.....	27
Plan the lift	27
Perform operator checks & inspections.....	28
Avoid or clear obstacles during travel	29
Stabilize the crane before rigging	30
Outrigger blocking guidelines	30
Pay attention to load limits and weight capacities.....	31
Factors influencing lifting capacity	31
Calculating load limits	32
Reading a load chart.....	35
Rigging the load	36
Rigger's Checklist	36
Basic rigging terms	38
Hitch Types	38
Communication & hand signals.....	42
General lifting techniques.....	43
Rules for slinging cargo	47
Emergency procedures.....	47
HAZARDS.....	48
Instability & tipping	48
Overload & collapse	49
Contact with power lines.....	50
Adverse weather	52
Falling objects	52
Entanglements.....	53
Pinch points	53
Dropped loads	54
Collisions	54
Other safety procedures	55
Lockout/tagout.....	55
Fall protection	56
Hazard communication.....	56
Personal protective equipment	56
APPENDIX A: General Crane Inspection Checklists	57
APPENDIX B: Overhead Crane Pre-Lift Inspection Checklist	59
APPENDIX C: Wire Rope Pre-Shift Inspection Checklist.....	61
APPENDIX D: Hoist Safety Inspection Checklist	62
APPENDIX E: Suspended Personal Platform Inspection Checklist	63
APPENDIX F: Helicopter Crane Critical Lift Operations Checklist....	62
APPENDIX G: Conveyor Belt Self-Inspection Checklist	63

REGULATORY COMPLIANCE



Standards that apply

- **Cranes & derricks**
[1926 Subpart CC](#)
- **Material hoists, personnel hoists, & elevators**
[1926.552](#)
- **Base-mounted drum hoists**
[1926.553\(a\)\(4\)](#)
- **Overhead & gantry hoists**
[1926.554](#) & [1910.179](#)
- **Conveyors**
[1926.555](#)
- **Electrical**
[1926 Subpart K](#)
- **Specific purpose equipment & installation**
[1926.406](#)
- **Fall protection**
[1926 Subpart M](#)
- **Power lines**
[1926.1407-1411](#)

New changes to safety standards

Historically employers performing construction-related activities followed OSHA's 1926.550 Cranes and Derricks Standard. Now there are new requirements under **OSHA Subpart CC** (the 29 CFR 1926.1400-1442 standards). Subpart CC updates industry work practices. It also addresses advances in the designs of cranes and derricks and the qualifications of employees needed to operate the equipment safely. There were a notable number of deaths associated with the use of cranes and derricks in construction. Based on years of extensive research and consultation with experts in the industry, OSHA took steps to better protect employees who work with or around cranes and derricks.

Employer Responsibilities

Employers have various responsibilities when using cranes and derricks in construction work, as outlined by OSHA regulations. These responsibilities also extend to other employers on construction sites where such equipment is used. The following are key points from the regulations:

- **Employers who own and operate cranes** must comply with all requirements of the standards if they have a crane operator who is their employee.
- **Employers operating leased cranes** cannot solely rely on the lessor's claim of compliance with OSHA's standard. They must verify this by requesting inspection reports or conducting their own annual inspection.
- **Crane lessors providing operators** must comply with all requirements of the standards and ensure safe operations.
- **Crane lessors sending mechanics for maintenance or repairs** must comply with qualifications for maintenance and repair workers and ensure that their actions do not expose other workers to hazards.

- **Contractors on construction sites** have responsibilities to protect their employees from hazards caused by the crane's or derrick's operation, including ensuring the equipments stability and providing training on craine or derrick hazards.
- **Training** is required for equipment operators, signal persons, competent and qualified persons, maintenance and repair workers, and workers near the equipment. You may be required to provide additional training depending on the circumstances.
- **When operating at a lumberyard or delivering materials to a construction site**, your duties under the standards depend on whether you place materials on the ground or onto a structure. If you only place materials on the ground without arranging them for hoisting, you are not subject to the standards. However, if you place materials onto a structure, the standards apply. Also, if you deliver prefabricated roof trusses and wall panels to a construction site using a flatbed truck equipped with an articulating crane, your duties under the standards depend on whether you unload the material onto the structure or onto the ground without arranging it for hoisting. If you unload onto the structure, you must comply with the standard.
- **General contractors have specific responsibilities when subcontractors bring cranes or derricks onto the site.** These duties include ensuring safe ground conditions, informing the subcontractor of any hazards, establishing a system to control multiple crane or derrick operations, and exercising reasonable care to prevent and detect violations on the site.
- **Employers have a responsibility to establish, effectively communicate, and enforce work rules to ensure compliance with the standard.** This includes ensuring that your employees, including the crane operator, follow the required actions outlined in the standard for maintaining a safe work environment.

Covered and excluded equipment under the standards

OSHA's crane and derrick standards apply to power-operated equipment used in construction work that can hoist, lower, and horizontally move a suspended load.

Covered equipment includes:

- Mobile cranes.
- Tower cranes.
- Articulating cranes.
- Derricks (except gin poles for communication towers).
- Floating cranes.
- Cranes on barges.
- Locomotive cranes.
- Multi-purpose machines when configured to hoist and lower (by means of a winch or hook) and horizontally move a suspended load.
- Industrial cranes (such as carry-deck cranes).
- Dedicated pile drivers.
- Service (Mechanics) trucks with a hoisting device.
- Monorail mounted cranes.
- Pedestal cranes.
- Portal cranes.

(continued)

Covered equipment continued:

- Overhead and gantry cranes (except if permanently installed in a facility (see [29 CFR 1910.179](#))).
- Straddle cranes.
- Sideboom cranes.
- Digger derricks (except when used for augering holes for poles carrying electric and telecommunication lines, placing and removing the poles, and for handling associated materials to be installed on or removed from the poles).
- Attachments used with covered equipment, such as hooks, magnets, grapples, and augers.

Excluded equipment includes:

- Equipment that would otherwise be covered while it has been converted or adapted for a non-hoisting use, which includes, but are not limited to:
 - Power shovels.
 - Excavators.
 - Concrete pumps.
 - Wheel loaders.
 - Backhoes.
 - Loader backhoes.
 - Track loaders.
- Machinery used with chains, slings, or other rigging to lift suspended loads, such as:
 - Automotive wreckers and tow trucks when used to clear wrecks and haul vehicles.
 - Digger derricks when used for augering holes for poles carrying electric and telecommunication lines, placing and removing the poles, and for handling associated materials to be installed on or removed from the poles. (See [29 CFR 1910.269](#), electric lines or [29 CFR 1910.268](#),

telecommunication lines

- Machinery originally designed as vehicle-mounted aerial devices (for lifting personnel) and self-propelled elevating work platforms.
- Telescopic (hydraulic) gantry systems.
- Stacker cranes.
- Powered industrial trucks (forklifts), except when configured to hoist and lower (by means of a winch or hook) and horizontally move a suspended load.
- Mechanic's truck with a hoisting device when used in activities related to equipment maintenance and repair
- Machinery that hoists by using a come-a-long or chainfall
- Dedicated drilling rigs.
- Gin poles when used for the erection of communication towers.
- Tree trimming and tree removal work.
- Anchor handling or dredge-related operations with a vessel or barge using an affixed A-frame.
- Roustabouts.
- Helicopter cranes.

Special rules apply to knuckleboom cranes used to deliver material to a construction site.

If the crane is used to transfer material onto the ground without arranging it for hoisting, it is not considered construction work and is not covered. However, if the material is transferred onto a structure, it is considered construction work. There are exceptions for sheet goods and packaged goods.

General Requirements

To ensure workplace safety when using cranes and derricks, OSHA provides the following guidelines:

- **Operator training.**
Operators must be properly trained and certified for the specific equipment they use. Training should cover safe operation, load capacity, inspections, and emergency procedures.
- **Regular inspections.**
Regular inspections are necessary to identify hazards and equipment defects. Pre-shift, periodic, and annual inspections must be conducted by qualified individuals. Documentation of annual inspections is required.
- **Equipment maintenance and repair.**
Employers are responsible for proper maintenance and prompt repair of equipment to prevent accidents or malfunctions.
- **Load capacity and stability.**
Employers must determine and not exceed the load capacity of the equipment. Stability is important, and equipment should be set up on stable ground or secured to prevent tipping or collapse.
- **Safety devices and controls.**
Proper safety devices and controls, such as emergency stop buttons and warning alarms, must be in place to prevent accidents and protect workers.
- **Fall protection.**
Fall protection measures, like harnesses or guardrails, must be provided for workers operating at heights.
- **Manufacturer's specifications.**
Follow the specifications and limitations provided by the equipment manufacturer. Do not make modifications without written approval.
- **Post important information.**
Post load capacities, speeds, warnings, and instructions where operators can see them.
- **Post American National Standards Institute (ANSI) standard hand signals.**
Post ANSI standard hand signals at the worksite for effective communication between operators and signal persons.
- **Guard moving parts.**
Guards should be in place to protect workers from moving parts like belts, gears, shafts, and pulleys.
- **Barricade swing radius.**
Barricade the swing radius of cranes to prevent unauthorized personnel from entering and getting struck.
- **Guard or insulate exhaust pipes.**
Guard or insulate exhaust pipes to prevent accidental contact and burns.
- **Monitor air and exhaust in enclosed spaces.**
Monitor air quality and exhaust in enclosed spaces to ensure a safe working environment.

- **Clear cab windows.**
Ensure cab windows have no distortion to maintain good visibility for operators.
- **Safe access to cab roof.**
Provide a ladder or steps for safe access to the cab roof.
- **Guardrails, handholds, and steps.**
Provide guardrails, handholds, and steps for safe entry and exit from the cab.
- **Anti-skid walking surfaces.**
Design walking surfaces to be anti-skid to reduce the risk of slips and falls.

- **Fire extinguisher.**
Have a fire extinguisher with a 5BC rating readily available for prompt response to fire emergencies.
- **Keep employees clear of suspended loads.**
Ensure no employees are near suspended loads to prevent accidents from falling objects or swinging loads.

These are the main points of the standards. Consult the full standards for a comprehensive understanding of all requirements and details.

Definitions

The [OSHA 29 CFR 1926.1401](#) provides important definitions related to the use of construction cranes and derricks. Some key terms include:

A/D Director (Assembly/Disassembly Director):

An individual who meets the standard's requirements for directing assembly and disassembly operations regardless of formal title or whether the person is management or non-management. They must be a "competent person" and a "qualified person," or a "competent person" assisted by one or more "qualified persons."

Assembly/Disassembly:

The process of assembling and disassembling cranes and derricks is covered under the standard. It must be carried out under the direction of an A/D Director. All assembly and disassembly operations must comply with either the procedures specified by the manufacturer or procedures developed by the employer that meet the criteria listed in [1926.1406](#). Under either alternative, procedures must comply with all manufacturer prohibitions.

Competent person:

Someone capable of identifying hazards and taking corrective measures. They must conduct shift and monthly inspections of all equipment. In general, a qualified crane or derrick operator who has the authority to take corrective measures will be a competent person under this definition.

Controlling entity:

This is an employer who is the prime contractor, general contractor, construction manager, or any other legal entity who has the overall responsibility for the construction of the project, including its planning, quality, and completion. The controlling entity is responsible for:

- Ensuring that the ground conditions are adequate to support the equipment.
- Informing the user and the equipment operator about the location of hazards beneath the equipment set-up area (such as

voids, tanks, and utilities) and if those hazards are identified in site drawings, as-built drawings, soil analyses, or other documents in the possession of the controlling entity (whether at the site or off-site). See section [1402\(c\)](#) for more details.

- Establishing a system to coordinate the operations of two cranes that operate within each other's working radius.

Dedicated spotter (power lines):

Dedicated spotters must meet the requirements of [29 CFR 1926.1428](#), Signal person qualifications. The spotter's sole responsibility is to watch the separation between the power line and the equipment; load line and load, including rigging and lifting accessories); and ensure through communication with the operator that the applicable minimum approach distance is not breached. The use of a dedicated spotter is one of the safeguards used to prevent a crane or derrick, as well as its load and load line, from breaching the applicable minimum distance from a power line, and thereby prevent death by electrocution, electric shock, and burn injuries. The minimum distances that must be maintained, and the safeguards that must be used, are addressed in sections [29 CFR 1926.1407](#), [1408](#), [1409](#), [1410](#), and [1411](#).

Electrical contact:

This occurs when equipment comes close to an energized conductor. Equipment (including the load and load line) coming into electrical contact with power lines is the leading cause of crane-related fatalities. It is important to remember that the equipment does not need to touch the power line to make electrical contact, as electricity can arc from a power line to nearby equipment.

Fall protection:

This includes various systems such as guardrails, safety nets, and personal fall arrest systems, as specified in OSHA's general fall protection requirements for construction as found in [29 CFR 1926 subpart M](#).

Qualified person:

A qualified person is someone who, by possession of a recognized degree, certificate, or professional standing, or who by extensive knowledge, training and experience, successfully demonstrated the ability to solve or resolve problems relating to the subject matter, the work, or the project. Numerous duties under the standard must be carried out by a person who meets this definition. These include conducting annual, comprehensive inspections of all equipment as well as inspections of modified equipment. A qualified person also is responsible for duties under various provisions of the standard, including those dealing with developing assembly and disassembly procedures, wire rope safety, fall protection, maintenance and repair, hoisting personnel, multiple crane or derrick lifts, equipment modifications, tower cranes, derricks, and floating cranes and derricks.

Rated capacity:

Rated capacity means the maximum working load permitted by the manufacturer under specified working conditions. Such working conditions typically include a specific combination of factors such as equipment configuration, radii, boom length, and other parameters of use. Workers have been killed and injured when cranes or derricks have collapsed because their rated capacity was exceeded. Compliance with the rated capacity is one of the most critical protective measures required by the standard.

These definitions are essential for employers and workers to ensure compliance with the regulations and maintain a safe work environment.

TYPES, COMPONENTS, & SETUP

Choosing the correct crane or derrick for the job is crucial for safe lifting. Different cranes and derricks are made for different tasks, so it is important to use the right one. This will make the project more efficient and keep everyone safe.

It is also important to take care of the equipment and keep it in good condition. All equipment should meet safety standards set by OSHA. Regular inspections and maintenance help prevent accidents and equipment

Choose the right equipment

Types of Cranes: While there are many types of cranes under each of the following categories, these are the primary classifications of cranes used in construction:

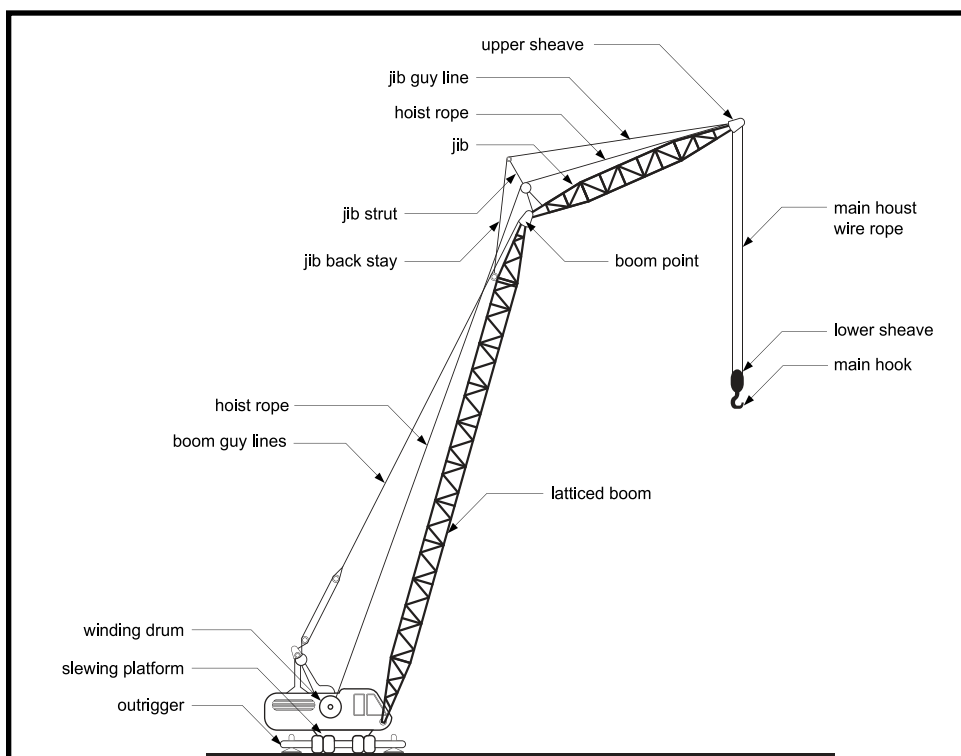

Mobile cranes.

These are the most common types of cranes used today. They can be easily transported to different worksites. Mobile cranes have a hook that is suspended from a boom using a wire rope. They are controlled by pulleys and cables from inside the crane. Mobile cranes can handle different types of terrain and are easy to assemble and set up.

The mobile crane in the diagram is shown with outriggers. The latticed boom is fitted with a jib.

Telescopic cranes.

These cranes are used for hauling and maneuvering operations, often in shipping ports. They are ideal for traveling on public roads and for off-road use due to the all-terrain chassis. They can also be used in rescue operations and for lifting boats from the water. Telescopic cranes have a large boom with several tubes fitted inside each other. A hydraulic system extends or retracts the tubes to increase or decrease the length of the boom.



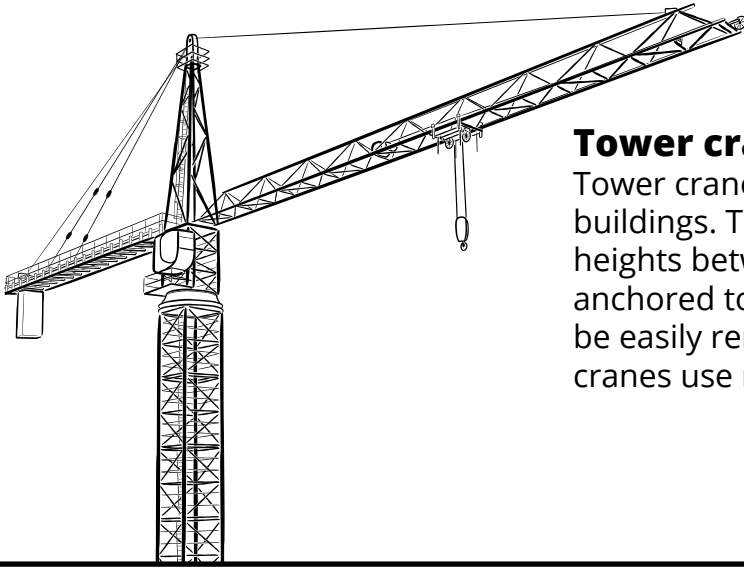

Tower cranes.

Tower cranes are used in the construction of tall buildings. They can lift heavy loads and work well at heights between 230 and 265 feet. Tower cranes are anchored to the ground during construction and can be easily removed afterward. Operators of tower cranes use radio and hand signals for communication.



Railroad cranes.

These cranes are specifically used for railway construction and repair, freight handling in rail yards, or accident recovery work. They have wheels that can move easily along railway tracks.



Aerial cranes.

Aerial cranes, also known as sky cranes or flying cranes, are helicopters used to lift heavy or awkward loads. They are often used to transport materials to hard-to-reach places, like the tops of high-rise buildings. Aerial cranes are also used in disaster rescue operations.

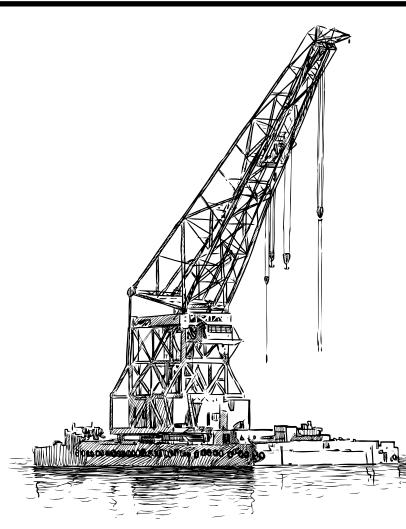

Floating cranes and harbor cranes.

These cranes are used for bridge or port construction. They can assist with loading and unloading cargo from ships. Floating cranes are fixed in place and can load up to about 9,000 tons. Harbor cranes are smaller and more flexible.

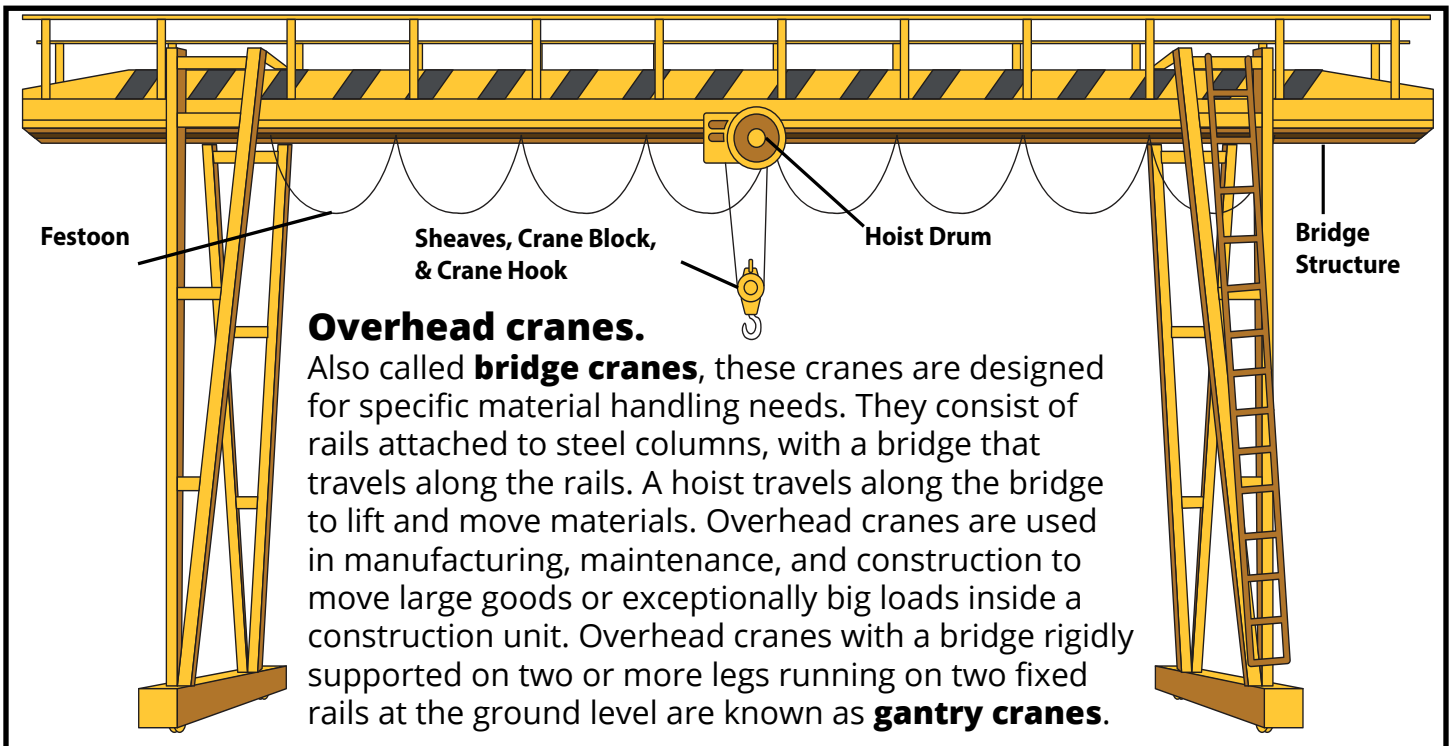

Types of Derricks:

Derricks can be found in a variety of construction projects, from high-rise construction to bridge building and many other infrastructure projects. The most basic type of derrick is controlled by three or four lines connected to a top mast, which allow it both to move sideways and up and down. A separate line runs up and over the mast with a hook on its free end, as with a crane. Below are the most common types of construction derricks:

Basket derricks. A basket derrick does not have a boom. It is supported by a rope-and-pole system that forms a basket shape. The load is lifted using a pulley system connected to the top of the tower.

Gin pole derricks. Gin pole derricks do not have a boom. This derrick consists of a single tower or mast supported by four guy wires, which allows the mast to be leaned in any direction. These derricks are often used as an improvised rescue derrick in emergencies.



Chicago boom derricks.

Chicago boom derricks have a boom attached to an external structure. The boom is connected to pulley systems to control its position. The load is lifted using a separate pulley system connected to the top of the boom.



A-frame derricks.

An A-frame derrick consists of a hinged boom attached to two upright members. The boom is secured to the junction of the upright members. The mast is braced or guyed from this junction point.

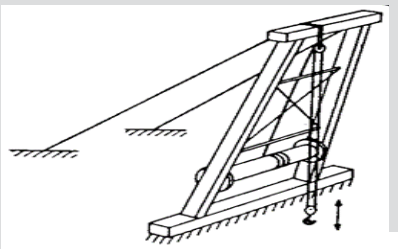
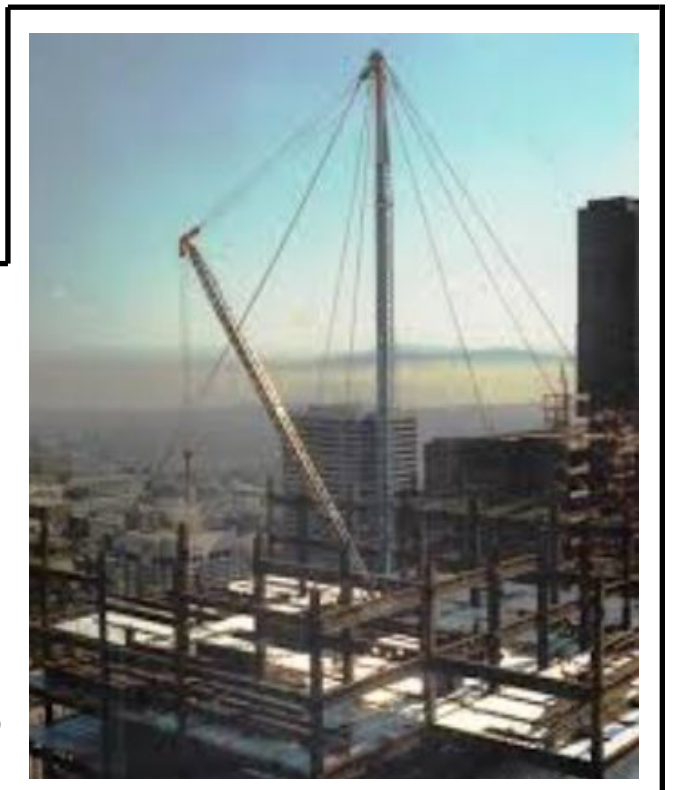

Breast derricks.

The breast derrick consists of a mast constructed from two upright members. Crossbars join the two members to form a mast.

Guy derricks.

This derrick consists of a fixed guyed mast that can be rotated and connected to a boom. The mast is upright and can rotate, but not lean. The load is lifted using a pulley system connected to the top of the boom.



Stiffleg derricks:

This derrick has a boom similar to a guy derrick. However, the top of the mast is secured by stiff members called stifflegs. These derricks are used for high-rise rigging and long-term jobs.

Shearleg derricks:

This derrick is similar to a breast derrick, but the top of the mast is secured by multiple guy wires. It is used to handle loads at various radii using a load tackle pulley system.



Basic components of cranes and derricks

Here are some basic parts of cranes or derricks, but the specific components and features can vary depending on the type of equipment and its intended use:

- **Anti-two block/limit switch.** This is a safety feature that prevents the hook block and load block from colliding. It uses a limit switch that triggers when the hook block is raised too high, signaling a crane's control system to stop the hoist to prevent a collision. It is a required safety feature in many places.
- **Boom.** This is the long arm of the crane or derrick that lifts and moves heavy loads. The boom can be fixed or telescopic, meaning it can extend or retract to different lengths.

- **Cab.** The cab, or cabin, is where the crane operator sits and controls the crane's movements. It is usually located at the top of the crane and provides a clear view of the construction site.
- **Center pin.** This part connects the different sections of the boom. It is usually located at the base of the boom and allows the boom to extend or retract as needed. The center pin is designed to handle heavy loads and is crucial for the crane's or derrick's lifting system (when applicable). Proper lubrication and maintenance are important to prevent damage and ensure safe operation.
- **Counterweight.** A counterweight is used to balance the weight of the load being lifted

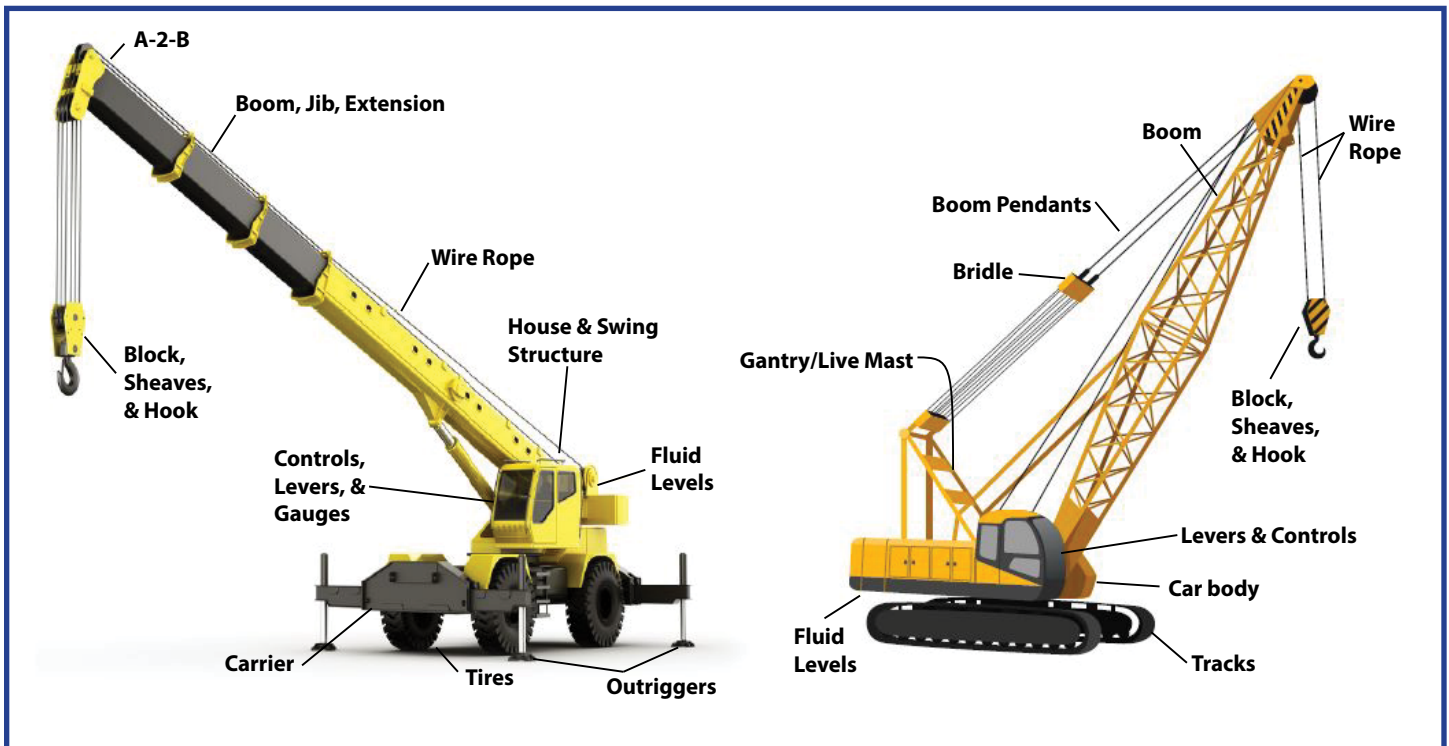

to provide stability to the crane or derrick. It is usually a large weight attached to the opposite end of the crane or derrick from the load.

- Hook.**
 This is the device at the end of the boom that attaches to, and lifts loads. The hook can be connected to different lifting equipment, like chains or slings. Cranes usually have two hooks: a main hook for heavy loads and an auxiliary hook for lighter loads or when assisting with lifting tasks. The auxiliary hook is often used to attach rigging equipment, like slings or chains, to the load being lifted. Having two hooks allows the crane operator to lift loads more efficiently and with more versatility.
- Jib.**
 Some cranes and derricks have a smaller arm called a jib attached to the end of the main boom. The jib can extend the reach of the crane

or derrick, and lift loads at an angle. Using a jib requires a third-party inspection certificate.

- Mast/Tower.**
 The mast gives the crane or derrick its height. Most masts have a triangular lattice structure that provides extra support during heavy crane or derrick lifting. Different lattice modules are connected to assemble the mast using screws to achieve the project's desired height. The mast's upper part usually has a rotating area, allowing 360-degree horizontal movement. You can also have a cab fitted on the mast.
- Outriggers.**
 Outriggers are extendable legs that give extra support and stability to cranes. They are used when lifting heavy loads or when the crane is on uneven ground. The outrigger leg extends perpendicular to the crane and is supported by a spreader plate,

which spreads the weight of the outrigger over a larger area.

- **Sheaves/pulleys.**
A grooved wheel within the hook block holds the pulley system's wire rope. This part allows for free movement of the wire rope while minimizing wear and tear. Also, the frictionless movement prevents premature damage to the hoist rope.
- **Spreader plates.**
These plates, also known as outrigger pads, prevent the outrigger from sinking into the ground. They provide a stable foundation for the crane. When the crane is not in use, the

outriggers can be retracted and stored on the crane itself. Using outriggers with spreader plates is an important safety feature that prevents the crane from tipping over during lifting operations.

- **Superstructure.**
This is the upper part of the crane or derrick that houses the machinery and components. Depending on the equipment, it may include the cab, engine, counterweights, or boom system. It needs to be strong and stable to support heavy loads and allow the crane or derrick to move precisely. Proper maintenance is necessary for safe and efficient operation.

IMPORTANCE OF GROUND CONDITIONS

Safe crane and derrick operations require suitable ground conditions to ensure the equipment's capacity and stability. As outlined in [29 CFR1926.1402](#), the ground must be firm, drained, and properly graded to meet the manufacturer's specifications for support and levelness. If the ground is muddy or unstable, the equipment can overturn, even if it is within the load limits set by the manufacturer.

Responsibility of the controlling entity

The responsibility for ensuring adequate ground conditions lies with the "controlling entity" at the construction site, such as the prime contractor or construction manager. They must make sure the ground is suitable and inform the crane or derrick operators of any hazards in the setup area, such as voids or utilities.

Responsibility of the company operating the crane

Although the controlling entity is responsible for providing adequate ground conditions, the company operating the crane is often in a better position to assess the ground conditions. If they find the conditions are inadequate, they must discuss the issue with the controlling entity and ensure the problem is resolved before starting or continuing operations.



ASSEMBLY & DISASSEMBLY GENERAL REQUIREMENTS



- o Provide adequate support and stability for all parts of the equipment.
- o Position employees involved in the assembly or disassembly operation in a way that minimizes their exposure to any unintended movement or collapse of the equipment.
- o Adhere to any manufacturer prohibitions that apply to the assembly or disassembly operation.

Accidents that occur during the assembly and disassembly of lattice boom and tower cranes are a leading cause of fatalities in this type of work. To prevent such accidents, specific procedures have been put in place for the safe assembly and disassembly. While hydraulic-boom cranes are typically not assembled on-site, there are still certain provisions that apply to equipment with hydraulic booms, such as the proper setting of outriggers and stabilizers. (See [29 CFR 1926.1404\(q\)](#)).

Required procedures

When assembling or disassembling a crane or derrick, there are two options for compliance. You may do one of the following:

- Follow the manufacturer's procedures.
- Develop your own procedures created by a qualified person. These procedures must, at a minimum:
 - o Prevent any unintended dangerous movement or collapse of the equipment.

Responsibility of the A/D Director

The assembly and disassembly operations must be directed by an individual who meets the criteria for both a competent person and a qualified person, or by a competent person who is assisted by one or more qualified persons. This person, known as the A/D Director, must have a thorough understanding of the applicable assembly and disassembly procedures. Among, but not limited to, the precautions an A/D Director must take to protect against potential hazards associated with the operation are:

- Ensure that the ground conditions can support the equipment during assembly and disassembly.
- Use the correct size and condition of blocking material to provide stability.
- Place blocking appropriately to protect the structural integrity of the equipment.
- Verify the capacity of an assist crane when used.

- Use suitable points of attachment for rigging to prevent structural damage.
- Identify the center of gravity of the load if necessary for stability.
- Rig or support boom sections and components to maintain stability.
- Prevent suspension ropes and pendants from catching on connection pins.
- Take steps to prevent unintended movement from inadequately supported counterweights. (Test the boom hoist brake before relying on it.)
- Ensure backward stability before swinging the upperworks.
- Consider the effect of wind speed and weather on the equipment.

Responsibility of the crew

The crew members involved in the operation must be fully aware of:

- Their tasks.
- The associated hazards.
- The positions and locations they need to avoid.
- Their required communication between the operator and the crew. They must communicate with the operator when going to a location that is out of view and could be potentially dangerous. The operator must

not move any part of the equipment until informed that the crew member is in a safe position.

Responsibility of the rigger

If rigging is used for assembly or disassembly, it must be done by a qualified rigger who meets the definition of a qualified person.

Avoid working under the boom

Employees should not be under the boom, jib, or other components when pins or similar devices are being removed, unless site constraints require it. In such cases, procedures must be implemented to minimize the risk of unintended dangerous movement and exposure under the boom.

Protect synthetic slings

When using synthetic slings during assembly or disassembly, employers must follow the manufacturer's procedures, even if they have their own procedures. Synthetic slings must be protected from sharp edges and anything that could reduce their capacity.





Use outriggers and stabilizers appropriately

When outriggers or stabilizers are required, they must follow these guidelines:

- Outriggers must be fully extended or deployed as specified in the load chart.
- Outriggers must take the weight off the wheels, except for locomotive cranes.
- Outrigger floats must be attached to the outriggers, and stabilizer floats must be attached to the stabilizers.
- The operator or a signal person must be able to see each outrigger or stabilizer during the extension and setting.
- Blocking must be placed under the float or pad of the jack or the outer surface of the outrigger or stabilizer beam.
- The blocking must be strong enough to support the loads and maintain stability.

Prevent movement when dismantling booms and jibs

During the dismantling of boom and jib sections, certain precautions must be taken to prevent dangerous movement:

- Pins in the pendants should not be removed when under tension.
- Pins on boom sections should not be removed when the pendants are in tension or when the boom is being supported by the uppermost section resting on the ground.
- Top pins on boom sections located on the [cantilevered](#) portion being removed should not be removed until the cantilevered section is fully supported.

Use fall protection

Fall protection is generally required when a worker is more than 15 feet above an unprotected side or edge during assembly or disassembly work. For more detailed information, please refer to [29 CFR 1926.1423](#).

WORKING NEAR POWER LINES

OSHA standards in 29 CFR 1926.1407-1411 provide specific procedures that employers must follow to prevent accidents caused by cranes coming into contact with power lines. These procedures aim to prevent electrical contact between the equipment and power lines and to protect workers in case of contact:

- **Maintain a safe distance.**
Operators must always keep a safe distance from power lines to avoid entanglement or contact. This is especially important when navigating through tight spaces or over obstructions. Minimum clearances are 20 feet for up to 350 kV and 50 feet for up to 1000 kV.
- **Calculate safe clearances if you know the voltage.**
If the voltage of the power line is known, Table A on page 23 provides the minimum clearance distance that can be used instead of 20 feet.
- **De-energize and ground lines.**
Whenever possible, coordinate with the power company to de-energize and ground the lines before performing work. If the lines are energized, notify the power company and determine the line voltage to ensure proper clearances.
- **Use additional safety measures as needed.**
Depending on the work practices and specific circumstances, additional safety measures may be necessary. These can include:
 - o Having a power line watcher.

- o Using warning signs.
- o Grounding the crane or derrick and load.
- o Implementing reenergizer lockout procedures.
- o Using insulated wire barriers.
- o Setting up work area barricades.
- o Using insulated tag lines.
- o Establishing radio contact between the operator and ground crews.
- o Installing limiters or proximity warning devices
- o Utilizing a fiberglass bottom.

- **Avoid operating below power lines.**

Operating below power lines is generally prohibited. No part of the equipment, load line, load, rigging, or lifting accessories are allowed below a power line unless:

- o The employer confirmed that the utility owner or operator has deenergized and visibly grounded the power line at the worksite.
- o The highest point of the equipment's boom, even if completely extended and vertical, will be more than the required minimum distance from the power line.

- **Comply with requirements when moving equipment.**

A crane traveling with a load must comply with the minimum clearance distance. If the crane is traveling with no load, the following clearance distances in Table B on page 23 must be maintained.

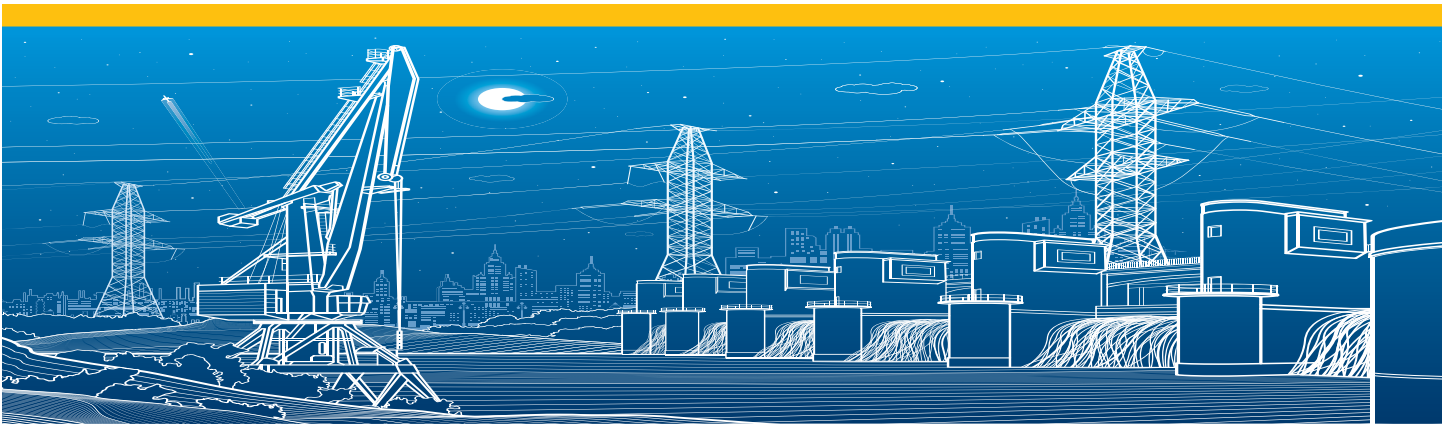

High Voltage Electrical Clearances

1st Choice

Power company to de-energize and ground the lines. Perform work.

2nd Choice

If lines are energized, notify the power company and determine line voltage in order to use Table A for clearances. If unknown line voltage, the minimum clearance is 20 feet up to 350 kV and 50 feet over 350 kV to 1,000 kV.

Work practices may require lift procedures, a line watcher, warning signs, crane and load grounding, re-energize lockout, insulated wire barriers, work area barricaded, insulated taglines, radio contact between the operator and ground crew, insulating link, limiter or proximity warning device, and fiberglass boom.

Table A - Minimum Clearance Distance

(OSHA 1926.1408/ASME B30.5)

Over ____ kV	Up to ____ kV	Feet	Meters
	50	10	3.05
50	200	15	4.60
200	350	20	6.10
350	500	25	7.62
500	750	35	10.67
750	1,000	45	13.72

Table B - Minimum Clearance Distances While Traveling with No Load (OSHA 1926.1410/ASME B30.5)

Voltage (nominal kV, alternating current)	While Traveling-Minimum Clearance (feet)
up to 0.75	4
over 0.75 to 50	6
over 50 to 345	10
over 345 to 750	16
over 750 to 1,000	20
over 1,000	(as established by the utility owner/operator or registered professional engineer who is a qualified person with respect to electrical power transmission and distribution)

USE ONLY TRAINED & QUALIFIED PERSONNEL

Always use trained and qualified personnel to set up, rig, signal, and operate the equipment. Ongoing training is also important so workers can stay updated on best practices, regulations, and advancements in equipment. The following information can improve workplace safety and efficiency.

Qualified operator

OSHA [29 CFR 1926.1427](#) requires only trained, certified, and properly evaluated individuals to operate cranes and digger derricks on construction sites.

- **Who needs to be certified or qualified?**

Any person involved in construction who operates a crane, except for those operating side boom cranes, derricks, and equipment with a hoisting/lifting capacity of 2,000 pounds or less must be certified and qualified.

- **Are operators of digger derricks required to be qualified or certified?**

Yes, unless the digger derrick is being used for specific tasks related to electric or telecommunication lines, these operators must be qualified and certified.

- **What is required for certification testing?**

Certification consists of a written examination covering safe operating procedures for the specific equipment the applicant will operate, as well as a technical understanding of the subject matter criteria. It also includes a practical exam to demonstrate the applicant's skills in safely operating the equipment, including the ability to use load chart information and perform shift inspections.

- **Does an operator need multiple certifications?**

An operator must be certified for the type and capacity of equipment they will operate, as determined by an accredited testing organization. Each organization establishes its categories for crane or digger type and capacity.

- **How can an operator be certified or qualified?**

There are four ways to meet OSHA requirements:

- **Obtain a certificate from an accredited crane or digger derrick operator testing organization.**

The organization must be accredited by a nationally recognized agency and tested according to specific criteria. The certification is transferable between employers and must be reviewed every 3 years. The certificate must indicate the type and capacity of the equipment for which the operator is certified, and it is valid for 5 years

- **Qualify through an audited employer program.**

An employer can provide a testing program overseen by an independent auditor. The auditor must be certified by an accredited testing organization and conduct audits according to recognized standards. Operator

qualification under this program is only valid while employed by the specific employer and operating a crane or digger derrick for them. The qualification is valid for up to 5 years.

- **Qualify through the US Military (only applicable to Department of Defense or Armed Forces employees, not private contractors).**

This qualification applies only to civilian employees of the Department of Defense or Armed Services and is

not transferable. It does not include employees of private contractors.

- **Obtain a license from a state or local government that meets OSHA's minimum requirements.** This license is obtained from a city or state with a certification program. It must meet OSHA's minimum requirements and is required for operators working within the jurisdiction of the issuing government entity. The license is not transferable and is valid for a maximum of 5 years.

Qualified rigger

Requirements for a qualified rigger are outlined in [29 CFR 1926.1401](#), [1926.1404](#), and [1926.1425](#).

- **When is a qualified rigger needed?**
Employers must use qualified riggers when hoisting during assembly and disassembly work. They are also required when workers are in the fall zone and involved in activities like hooking, unhooking, or guiding a load. They are also required when making the initial connection of a load to a component or structure.
- **What is required to be a qualified rigger?**
A qualified rigger is someone who meets OSHA's criteria for a [qualified person](#). Employers must determine if a person is qualified for specific rigging tasks. Each qualified rigger may have different credentials or experience. A qualified rigger can be someone with a recognized degree, certificate, or professional standing, or someone with extensive knowl-

edge, training, and experience who can demonstrate problem-solving abilities related to rigging loads.

- **Does a rigger have to be qualified in all rigging jobs?**
The qualified rigger designated for a job must have the ability to properly rig the load. However, it doesn't mean they have to be qualified for every type of rigging job. Each load has unique properties, and a rigger may have experience in certain types of rigging but not others. Employers need to ensure that the person can handle the rigging work required for the specific types of loads and lifts for a particular job.
- **Do qualified riggers have to be certified?**
Qualified riggers do not have to be trained or certified by an accredited organization or assessed by a third party. While employers can choose to have a third party assess the qualifications of a rigger candidate, it is not mandatory.

- **Are certified crane or digger derrick operators also qualified riggers?**
Being a certified operator does not automatically make someone a qualified rigger. Whether a person is a qualified rigger depends on the nature of the load, lift, and equipment used, as well as their knowledge and experience with rigging. A certified and qualified operator may meet the requirements of a qualified rigger, depending on their rigging knowledge and experience.

Qualified signal person

- **How does a signal person become qualified?**
The employer must make sure that signal persons meet certain requirements before they can give signals. There are two options to meet these requirements:
 - **The signal person has documentation from a qualified evaluator showing they meet the requirements.**
 - **The employer's qualified evaluator assesses the person and determines if they meet the requirements.**
- **Does the signal person's qualifications have to be documented?**
Yes. The employer must have documentation available at the worksite to show which option was used and which signals were learned. If the signal person's actions later show that they don't meet the requirements, the employer must stop them from working as a signal person until they receive re-training and pass another assessment.
- **What are the requirements to become a qualified signal person?**
The requirements for signal persons include knowing and understanding the signals used, being competent in using those signals, having a basic understanding of equipment operation and limitations, knowing the relevant requirements, and demonstrating their knowledge through tests.

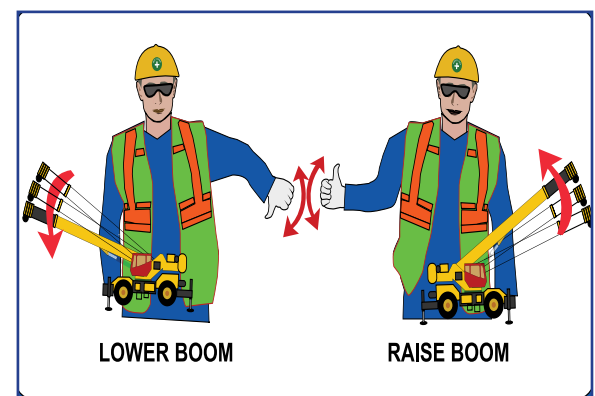
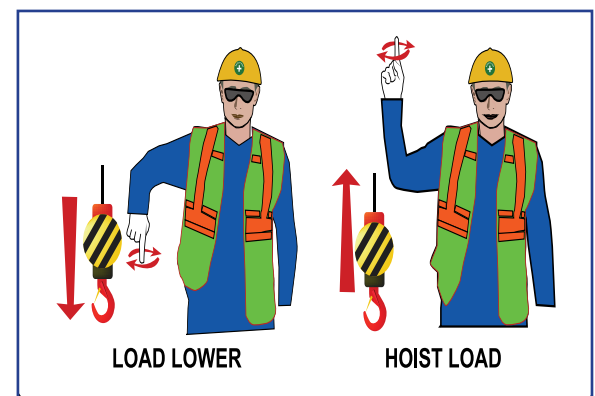

See page 42 for a complete set of mobile crane hand signals.

LIFTING & MOVING LOADS

Safe and effective handling of loads is a major safety concern when using cranes and derricks in construction. It is important to understand the capacity of the load, the proper ways to secure it, and how to ensure its stability to keep both people and equipment safe. The following information can improve workplace safety and make load handling more efficient.

Review manufacturers' manuals

Even when employing qualified personnel, it is important to remember that cranes and derricks from different manufacturers have unique controls, failsafe devices, and features. Anyone operating or working with cranes and derricks should have a detailed understanding of the specific equipment being used. Always refer to the manufacturer's operating manual. It includes vital information about:

- Load capacities.
- Safety mechanisms.
- Stabilizers and counterweights.
- Operator controls.

Always read the operator's manual in full before operating any crane or derrick.

Plan the lift

Before you start lifting anything, it is important to plan. Take the time to assess the load and the area where you will be lifting:

- What are the conditions at the work site?
- What is the terrain like?
- What is the weather like?
- Are there potential hazards or obstacles?
- Is a site survey needed?
- Is there enough space?
- Have all power lines been identified?

- Are conditions such that starting the project needs to wait until things improve?

Next, determine how heavy the load is:

- How much is going to be lifted?
- How much weight can the crane or derrick handle?

Every crane and derrick has a limit to how much it can lift. If employees go over that limit, the equipment can get damaged or drop the load. This puts workers below at risk of getting hurt or even killed. Adjust the loads accordingly to stay within the crane's capacity.



Perform operator checks & inspections

Always Perform Daily Operator Checks Before Using Cranes or Derricks



Begin with **pre-start checks** to ensure the equipment's basic features are in working order.



Complete **engine start-up checks** to confirm that the equipment is ready for operation.



Perform **safety system checks** to verify that fail-safes are in place to prevent accidents.

Inspect the equipment, wire rope, wire rope slings, and assemblies regularly. OSHA has the following crane and derrick inspection requirements:

- **Cranes and derricks must be inspected by a competent person who can identify potential hazards.**

OSHA requires the employer to designate a competent person to inspect the equipment. This must be a person familiar with equipment's components and capable of identifying potential hazards. They also must be authorized to take measures to eliminate those hazards if any are found.

- **Functional tests of the equipment must be performed.**

Cranes and derricks must be inspected before each use, including the initial use, to prevent any potential problems or injuries that could occur while using the equipment. A functional test evaluates how the crane or derrick works and if it is operating normally. The person selected to perform the inspection must look at and test all critical components, including the control system, braking system, power plant, and load-sustaining structural components like the hoisting equipment.

- **Inspections must be frequent and periodic:**

- **Frequent.**

Frequent inspections occur daily, weekly, or monthly. They are designed to test the crane or derrick for function and proper operation. These are designed to make sure parts like the hydraulic system, hooks, and hoist chains are working properly.

- **Periodic.**

Periodic inspections can occur bimonthly, quarterly, or yearly. These are designed to evaluate the overall wear of the crane or derrick, such as sheaves, rivets, sprockets, and brakes. Annual inspections must be conducted on or before the anniversary date of the last annual inspection and must be documented.

- **Crane and derrick operators must inspect equipment daily before each use.** These checks include:

- **Pre-start checks.**

Before starting the crane, the oper-

ator should check the tire condition, oil levels, seat belts, air reservoir, and the battery, as applicable.

- **Engine start-up checks.**

Before daily work begins, the operator should start the engine, and check the pressure gauge fuel level, turn signals, horn, suspension, and brain system, among other things, as applicable.

- **Safety system checks.**

Most importantly, safety system checks should be performed to prevent accidents. Make sure to evaluate the anti-two-block, the rated capacity limiter, and the outrigger, as applicable.

- **Hydraulic system checks.**

Please consult the worksite's daily operator checklist for a specific list of tasks for each piece of equipment.

Sample inspection checklists are available in the appendices of this document. However, each employer should design specific, thorough checklists based on their equipment and working conditions.

Avoid or clear obstacles during travel

Before a mobile crane starts moving or any crane or derrick is transported, it is important to plan and clear a path of any obstacles. If there are hazards that cannot be moved, like power lines or permanent features, the equipment should stay away from them, and the operator should maintain a safe distance.

[Regulations require](#) that cranes and derricks must stay at least 10 feet away from power lines up to 50,000 volts. Additionally, a signal person should always lead a crane or derrick during travel, alerting the operator to potential hazards and warning other site personnel about the crane's or derrick's movement.



Stabilize cranes before rigging

Always Stabilize the Crane Before Operation

- Extend outriggers according to **manufacturer's guidelines**.
- Always use **outrigger pads** or **crane pads**.
- Never place outriggers over **voids, depressions, or unsteady ground**.

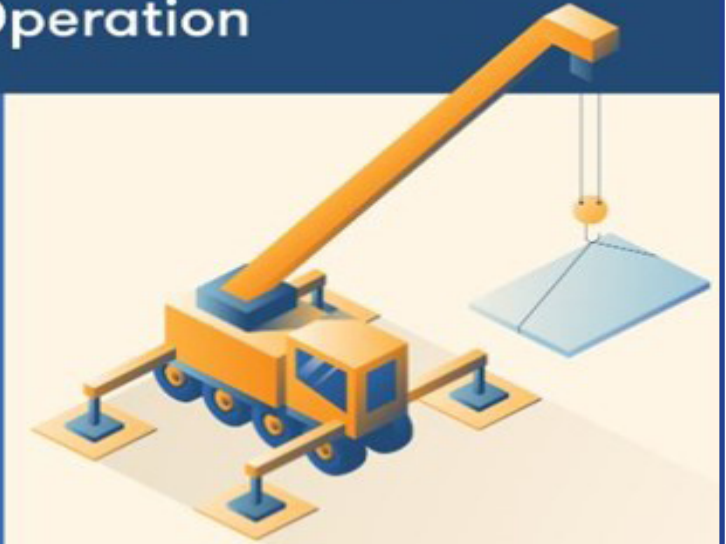

Mobile cranes use outriggers or other stabilizing features to prevent tipping during operation. When stabilizing the crane, keep the following in mind:

- Follow the **manufacturer's guidelines** for extending outriggers.
- Always use **outrigger pads** or **crane pads** underneath outriggers.
- Avoid placing outriggers over **voids, depressions, or unstable ground**.

Improper outrigger setup is a common cause of crane accidents and tip-overs. A solid safety assessment of outrigger placement is needed.

Outrigger blocking guidelines

Proper outrigger blocking is required to distribute the weight of the crane and the load over a greater surface to prevent tipping. The Outrigger Blocking Chart to the right can provide safe guidelines.

To use the chart below, first determine the crane's tonnage (on the vertical axis). Go right, intersecting the soil type, then down to the square feet required. The crane operator, if uncertain about the soil type, should always seek advice from a soil engineer to determine the stability, compaction, and cohesion of the soil.

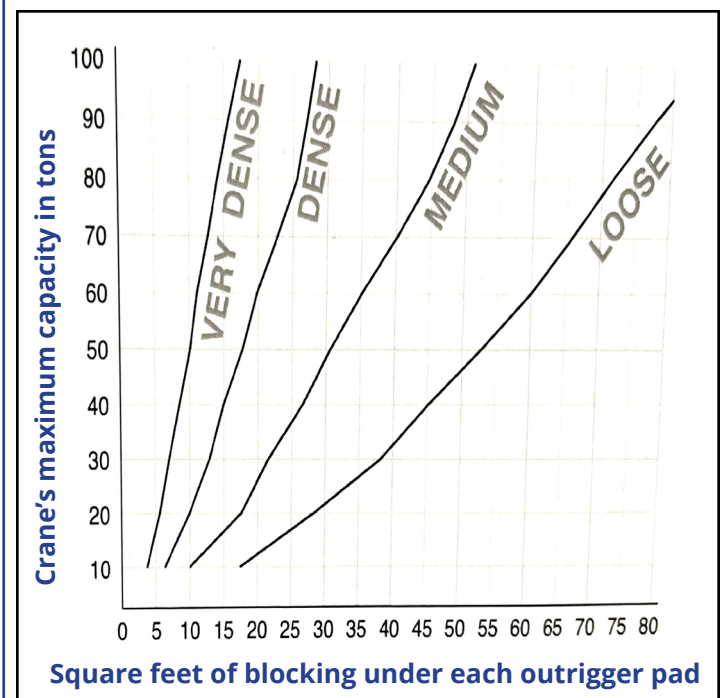

Pay attention to load limits and weight capacities

Always Adhere to Weight Limits on the Load Chart

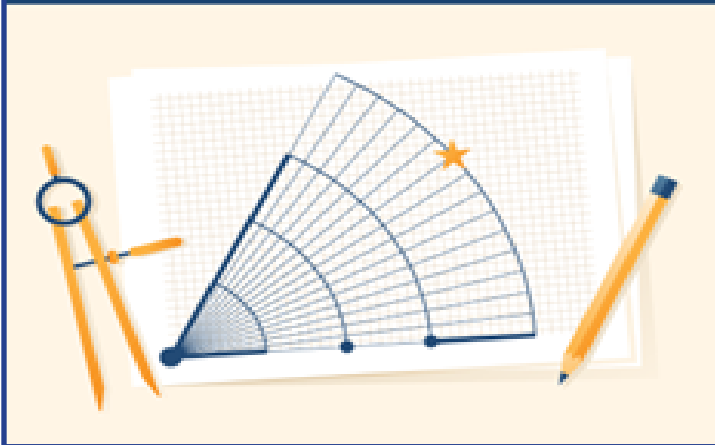

- A crane holds **more weight on outriggers** than on rubber.
- A crane holds **less weight when rotation and swings** are involved.
- When the **load radius is higher**, the crane holds **less weight**.

Factors influencing lifting capacity

The elements that determine the lifting capacity of a crane or derrick include:

- **Boom length.**
This refers to the distance from the base of the crane or derrick to the tip of the boom (the extendable arm of the crane). The boom length has a direct impact on the lifting capacity – **the longer the boom, the lower the capacity.**
- **Dimensions and weight.**
The physical dimensions and weight of the crane or derrick play a significant role in determining its lifting capacity. A larger, heavier crane or derrick typically has a higher lifting capacity than a smaller, lighter one. However, the size and weight of the equipment also affects its stability, mobility, and the space it requires on the job site.

(continued)

Possible weight considerations

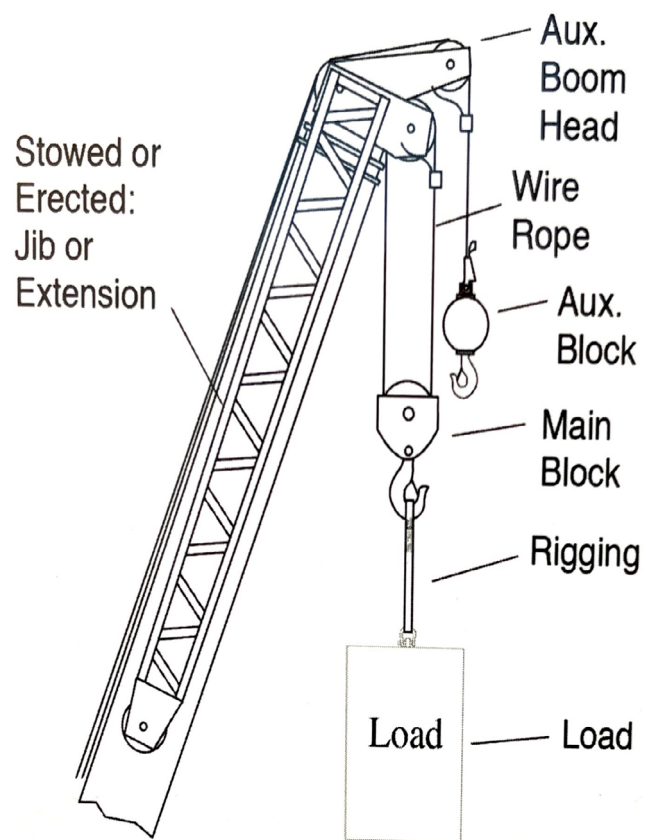

Factors influencing lifting capacity

(continued)

- Lift Angle.**
 The lift angle, or the angle between the load and the boom, is a significant factor in determining the lifting capacity of the equipment. As the angle decreases, the load's stress on the crane or derrick increases, thus reducing its lifting capacity. Therefore, it is essential to maintain an optimal lift angle to maximize the lifting capability safely.
- Lift Range.**
 The lift range is the distance between the lowest and highest point that a crane or derrick can lift a load. The range directly affects the lifting capacity of the equipment. Usually, a crane or derrick can lift heavier loads within a shorter lift range. As the range increases, the equipment's lifting capacity decreases. Therefore, understanding the lift range is essential to ensure the crane or derrick can handle the load throughout the entire range of the lift.
- Lifting Height.**
 This is the vertical distance from the ground level to where the load will be placed. As the height increases, it can also limit the lifting capacity due to stability and balance concerns.
- Radius:**
 Radius is the horizontal distance from the center of rotation of a crane to the center of the load. Like boom length, a larger radius reduces the crane's lifting capacity.
- Stroke.**
 The stroke refers to the total movement of the piston in the cylinder. In the case of hydraulic cranes, the stroke influences the crane's lifting capacity. A longer stroke means a greater range of motion, enabling the crane to lift heavier loads. However, operators must be cautious because a longer stroke also puts more stress on the equipment, which could lead to instability if not properly managed.

Calculating load limits

Materials & liquids	Pounds/cubic feet
Aluminum	165
Asbestos	153
Asphalt	81
Brass	524
Brick	120
Bronze	534
Coal	56
	150
Crushed Rock	95
Diesel	52
Dry Earth, Loose	75
Gasoline	45
Glass	62
Iron Casing	450
Lead	708
Lumber-Fir	32
Lumber-Oak	62
	50
Oil, Motor	58
Paper	58
Portland Cement	94
River Sand	120
Rubber	94
Steel	480
Water	63
Zinc	437

Calculating load limits	
Steel Plate	Pounds/cubic feet
1/8"	5
1/4"	10
1/2"	20
1"	40
Aluminum Plate	Pounds/cubic feet
1/8"	1.75
1/4"	3.50
Lumber	Pounds/cubic feet
3/4" Fir	2
3/4" Oak	4
Liquids	Pounds/gallon
Gas	6.0
Diesel	7.0
Water	8.3

Formulas & information for calculating load limits
7.5 gallons of liquid to a cubic foot
27 cubic feet to a cubic yard
2,000 pounds to 1 U.S. ton
H=Height; W=Width; L=Length; d=diameter; r=radius
$r=1/2$ diameter; $\pi=3.2$ (approximately)
Area of a square or rectangle=HW
Volume of a cube=HWL
Area of a circle= πr^2
Circumference= πd
The area of a circle is approximately 80% of its diameter squared (diameter x diameter)

Finding the load capacity

Understanding the terms associated with the equipment's load capacity and properly calculating the weight of the load being lifted is crucial. Ensure that the weight falls within the rated capacity of the equipment to make informed decisions.

Lifting capacity.

Also known as rated capacity, it refers to the maximum load weight a sling or piece of hardware or equipment can hold or lift.

Load.

The total weight of what is being lifted, including all slings, hitches, and hardware.

Weight capacity.

The maximum amount of weight that a structure can safely support.

To determine the load capacity of a crane or derrick, it is important to consult the load chart. Load charts provide information on the equipment's capacity at different boom lengths and lift angles and show how **the capacity decreases as the boom length increases.**

While many modern cranes and some derricks have **load moment indicators (LMIs)** and **rated capacity limiters (RCLs)**, equipment operators should still know how to read load charts for a safe lift. When reading load charts, keep the following in mind:

⚠ **WARNING**



**Do Not Exceed
Work Load Limit
["WLL"]**

- **Rubber versus outriggers.**

Cranes can handle more weight when they are on outriggers than on tires. The load chart has different columns to represent this.

- **Rotation.**

A crane or derrick can handle more weight if the boom stays over the front of the equipment throughout the lift. Capacity is lower if the boom needs to swing, so refer to the correct column.

- **Load radius.**

Load radius is influenced by the boom angle and the length of extensions on a telescopic crane. When the boom angle is higher, the load is closer to the crane's center line and the boom can carry more weight. When the boom angle is lower, the load is further from the center line and the boom can hold less weight.

Each crane and derrick model has its unique load chart, which is typically provided by the manufacturer in the operator manual.

HOW TO FIND A CRANE'S LOAD CAPACITY USING THE LOAD CHART

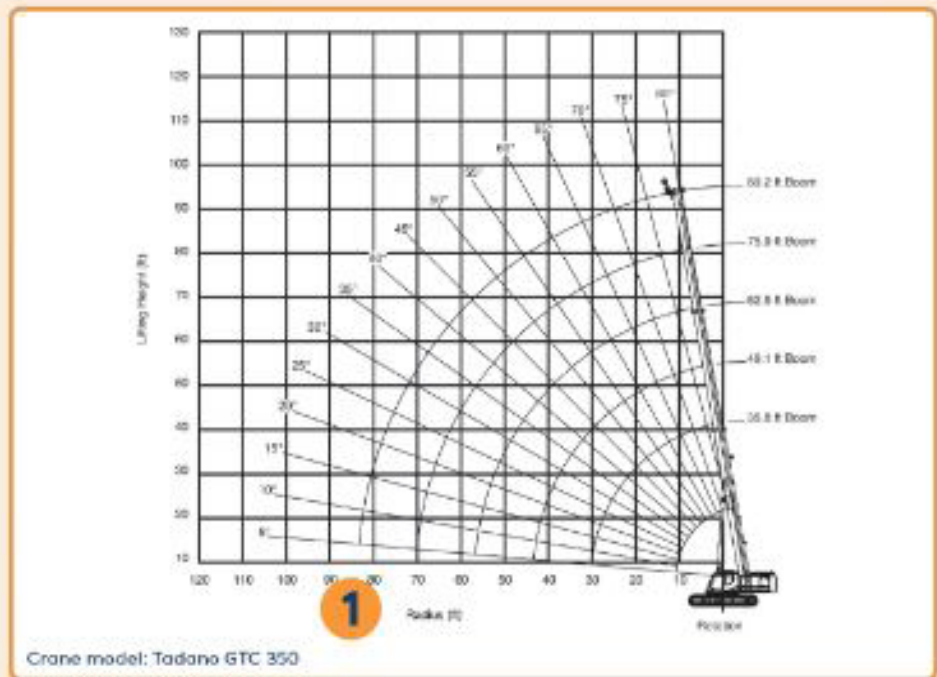

Tracks fully extended = 300" - Up to 0.5° slope

12,500 lb 15' 9" 0.5° 20 mph 360° ASME B30.5

	35.8 ft	48.1 ft	63.5 ft	75.9 ft	89.2 ft	
h			5,000 lb			ft
8	70.5	48.5	48.8	-	-	8
10	70.5	48.7	48.7	-	-	10
12	70.5	48.7	48.9	34.2	-	12
15	49.5	48.7	48.5	33.2	23.8	15
20	50.3	50.4	50.2	28.4	23.5	20
25	21.3	21.4	21.4	21.4	20.1	25
30	10.1	16.2	16.2	16.2	16.2	30
35	-	12.8	12.8	12.8	12.8	35
40	-	10.4	10.4	10.4	10.4	40
45	-	-	8.7	8.8	8.7	45
50	-	-	7.3	7.4	7.4	50
55	-	-	6.3	6.3	6.3	55
60	-	-	-	5.4	5.4	60
65	-	-	-	4.7	4.7	65
70	-	-	-	4.1	4.1	70
75	-	-	-	-	3.6	75
80	-	-	-	-	3.2	80
TRACKS	6	6	6	4	4	

Crane model: Tadano GTC 350

- 1 Use the range diagram to calculate the load radius based on the boom angle and length.
- 2 Find the load radius on the load chart to see the lifting capacity for the crane's configuration.
- 3 Analyze the load chart to see how environmental factors and accessories affect the capacity.

Reading a load chart

Here is how to use a load chart for a crane:

1. Calculate the load radius.

The load chart will have a lift range diagram showing the load radius, which is the horizontal distance between the centerline of the crane's rotation and the load. The shorter the load radius, the higher the crane's capacity. Find the boom length and angle on the diagram and look for the corresponding number at the bottom of the chart to determine the radius.

2. Look up the crane lifting capacity.

Once you have the load radius, locate it on the load chart and check the corresponding lifting capacity. The chart will usually provide both the gross capacity and net capacity of the crane. Factors such as the machine's stabilization method (tires or outriggers), position (rear or front), and rotation angle can affect the net capacity. Ensure that the crane configuration and any attachments or accessories are considered.

3. Consider environmental factors.

Environmental factors like ground conditions (slope) and wind speed also impact the crane's stability and load capacity. Take these factors into account when referring to the load chart.

If/Then Guidelines

IF the known radius falls between two values on the load chart,
THEN use the next longer radius listed on the load chart.

IF the known boom length falls between values listed on the load chart,
THEN select the smallest capacity (longer or shorter boom length) to determine the crane capacity.

IF the crane's known boom angle falls between two values on the load chart,
THEN use the next lower boom angle listed on the load chart.

A typical crane load chart includes:

- **Lifting capacity.**
- **Boom length.**
- **Boom angle.**
- **Capacity deductions for accessories.**
- **Operation notes regarding slope and wind speed.**

The chart may also have a **bold line that separates the crane's capacity limitations** based on structural strength and stability.

Remember, it is important to consult the specific load chart for the crane model being used and follow all safety guidelines and regulations.

Rigging the load

Once the load capacity is known, select the appropriate rigging equipment such as slings, shackles, and hooks. Before each use, inspect the rigging gear for any defects or damage to ensure safe lifting operations.

When rigging a load, consider the following:

- **Hitching.**
There are different ways to attach slings to a load, so consider the object being lifted and its weight distribution. Basket hitching and choker hitching are common configurations.
- **Sling angle.**
When using an angle other than vertical, additional forces are exerted on the slings, reducing their weight capacity. Use slings that are properly rated for both the weight and the angle.

Understanding force, weight distributions, and rigging techniques will ensure a safe and stable lift, even with irregular and heavy loads.

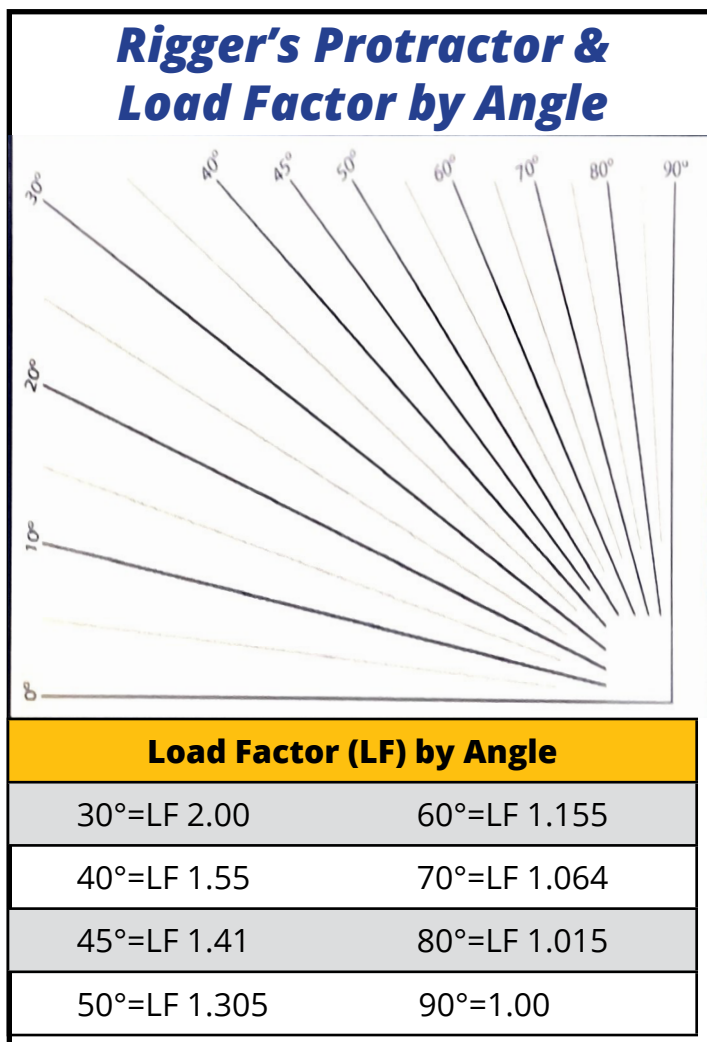

Rigger's checklist

- **Know the weight and measurements.**
Before lifting, make sure you know the exact weight of the load, how far you need to move it, and how high you need to lift it. Ensure that the load's weight falls within the sling's rated capacity, considering the angles and physical parameters of the load.
- **Use the right connection.**
Determine how to attach the load to the lifting hook and how to connect the sling to the load.
- **Choose the right sling.**
Each load is unique. Calculate the correct rated capacity for the angles and connection method and select the right type and style of sling for the job. If the D/d ratios – the ratio of the diameter around which the sling is bent, divided by the body diameter of the sling -- are smaller than recommended, reduce the sling's rated capacity. Use a sling with the proper end attachments or eye protection and pad all corners in contact with the sling to minimize damage.

Rigger's checklist

(Continued)

- Inspect the sling.**
 Thoroughly check the sling to ensure it is in good condition and capable of making the lift. Follow OSHA guidelines. Remember that you cannot alter the length of a sling; if a different length is needed, obtain a sling of the required length.
- Attach the sling to the load first.**
 Always connect the sling to the load before attaching it to the hook.
- Balance the load.**
 Place the eye or link of the sling in the base (bowl) of the hook to prevent point loading. When using a basket hitch, ensure the load is balanced to prevent slippage. The sling's legs should support the load from the sides above the center of gravity in a basket hitch. Make sure the slings are long enough to provide adequate rated capacity when considering the angle of the legs.

- Test the rigging.**
 Before lifting, lightly tug on the rigging to ensure that blocking, sling, and load protection are in place. Lift the load slightly off the ground and recheck the setup.
- Stand clear and lift.**
 To avoid injury, keep away from the areas between the sling and load, as well as between the sling and the crane or derrick and its hoist hook. Let the lifting device and rigging do the work for you. Use a tagline or tether and stay clear of the suspended load.
- Avoid sudden movements.**
 Lift slowly and steadily, without sudden starts or stops, both when lifting and swinging the load.
- Store the sling properly.**
 After completing the lift, inspect the sling for any damage. If it is damaged and unusable, dispose of it immediately. Otherwise, return it to the sling storage rack until the next lift.

Wire rope weights				
Wire rope diameter		Weight per foot in pounds by rope classification*		
Inches	mm	6 x 9 IWRC (Independent Wire Rope Core)	19 x 7	19 Strand Compacted
1/2	13	.46	.45	.54
9/16	14.5	.59	.58	.69
5/8	16	.72	.71	.85
3/4	19	1.04	1.02	1.25
7/8	22	1.42	1.39	1.68
1	26	1.85	1.82	2.17
1 1/8	29	2.34	2.30	2.75
1 1/4	32	2.89	2.84	3.45

*These values represent industry averages; when weight is critical, always check the manufacturer's information for exact values.

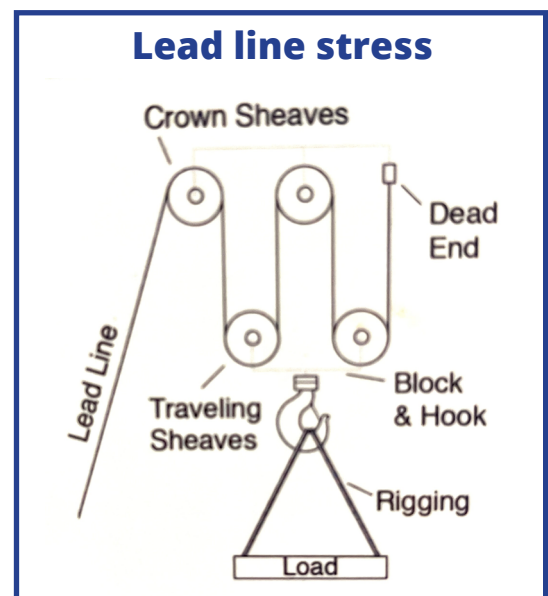

Basic rigging terms

Here are some basic terms used in rigging:

ASME hand signals:

Communication signals established by the American Society of Mechanical Engineers and used for guiding the movement of loads for mobile and overhead cranes.

Block and tackle:

A simple system of ropes and pulleys used to lift loads.

Blocking:

Also known as cribbing, it refers to the material used to support a load or allow the removal of slings after the load is landed.

Bridle:

A configuration that uses two or more slings to connect a load to a single hoist hook.

Bull Ring:

A single ring used to attach multiple slings to a hoist hook.

Core:

The center support member of a wire rope around which the strands are laid.

Cribbing:

Material used to either support a load or allow removal of slings after the load is landed. Also called blocking.

Hitch Types

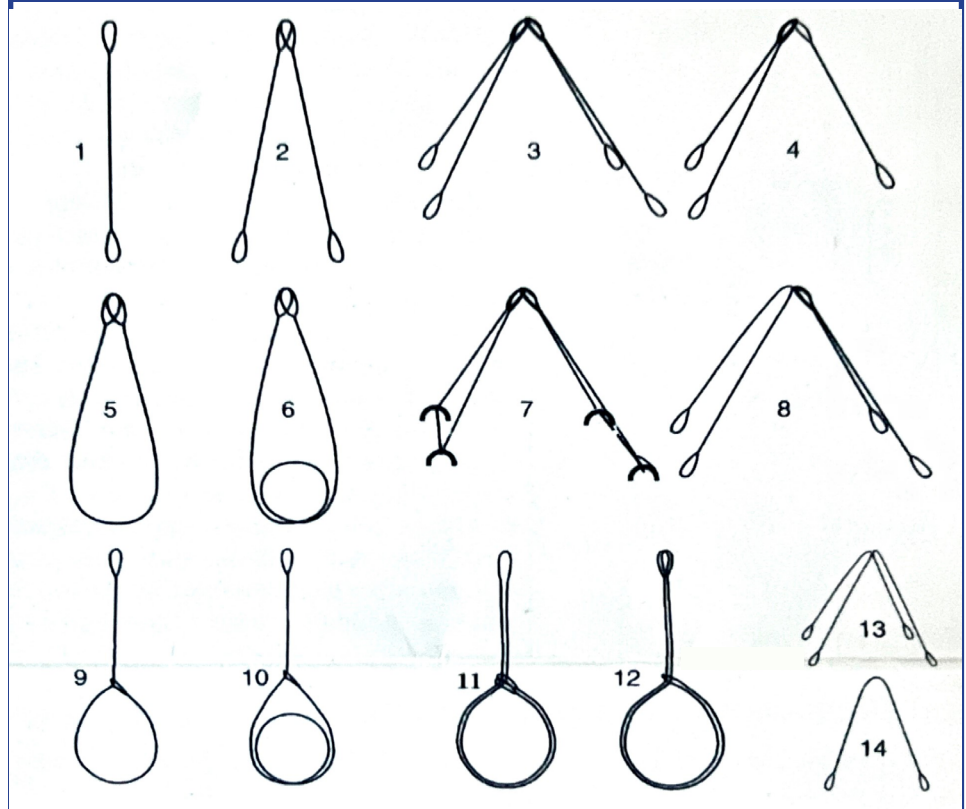

#	Hitch type	↑/CG	Leg loading	Load control	#
1	Single Vertical	Above	One	Poor	1
2	2-Leg Bridle	Above	Two	Average	2
3	4-Leg Bridle	Both	Two	Excellent	3
4	3-Leg Bridle	Both	Three	Excellent	4
5	Single Wrap Basket	Both*	Two	Average	5
6	Double Wrap Basket	Both*	Two	Good	6
7	Two Single Baskets	Both**	Four	Poor	7
8	Inverted Basket & 2-Leg Bridle	Both	Four	Excellent	8
9	Single Wrap Choker	Both*	Single	Average	9
10	Double Wrap Choker	Both*	Single	Good	10
11	Double Choker Bight-up	Both*	Two	Good	11
12	Double Choker Eyes-up	Both*	Two	Poor	12
13	Double Inverted Baskets	Above	Four	Poor	13
14	Single Inverted Basket	Above	Two	Poor	14

**never us as a single hitch below CG*

***Compounds loading at pick points*

Basic rigging terms

(Continued)

D/d ratio:

The ratio of the diameter around which the sling is bent, divided by the body diameter of the sling.

Eyebolt:

A piece of rigging hardware used to attach a sling to a load.

Grommet sling:

A sling made in an endless loop.

Hitch:

The rigging configuration by which a sling connects the load to the hoist hook. The three basic types of hitches are vertical, choker, and basket.

Hoist:

A device that applies mechanical force to lift or lower a load.

Lifting clamp:

A device used to move loads, such as steel plates or concrete panels, without the use of slings.

Lifting capacity:

Also known as rated capacity, it refers to the maximum load weight a sling or piece of hardware or equipment can hold or lift.

Load:

The total weight of what is being lifted, including all slings, hitches, and hardware.

Load control:

The safe and efficient practice of manipulating a load using proper communication and hand techniques.

Wire rope diameter		6 strand (3.5 : 1 design factor)			Rotation Resistant (5 : 1 design factor)			
inches	mm	6x19 IPS (Improved Plowed Steel) IWRC (Independent Wire Rope Core)	6 x 19 EIPS (Extra Improved Plowed Steel) IWRC	6 x 19 EEIPS (Extra Extra Improved Plowed Steel) IWRC	8 x 19 EIPS	19 x 7 EIPS	19x 19 Compacted Strand High Strength	35 x 7 Compacted Strand High Strength
1/2	13	3.2	3.8	4.1	2.3	2.1	2.9	3.1
9/16	14.5	4.1	4.8	5.2	2.9	2.7	3.7	3.7
5/8	16	5.0	5.8	6.4	3.5	3.3	4.5	4.9
3/4	19	7.3	8.4	9.2	5.1	4.8	6.4	6.8
7/8	22	9.8	11.3	12.5	7.0	6.5	8.7	9.3
1	26	12.8	14.7	16.2	9.1	8.4	11.3	12.8
1 1/8	29	16.1	18.5	20.4	11.4	10.6	14.3	15.0
1 1/4	32	19.8	22.8	25.1	14.1	13.0	17.5	19.8

* These values represent industry averages; always confirm the design factors and rated capacities based on the appropriate manufacturer's available data from the crane's or derrick's load chart or published catalog.

Basic rigging terms

(Continued)

Load stress:

The strain or tension applied to the rigging by the weight of the suspended load.

Master link:

The main connection fitting for chain slings.

One rope lay:

The lengthwise distance it takes for one strand of a wire rope to make a complete turn around the core.

Pad eye:

A welded structural lifting attachment.

Plane:

A surface in which a straight line joining two points lies entirely within that surface.

Rejection criteria:

Standards, rules, or tests used to determine if an object or device should be removed from service because it is no longer safe.

Rigging hook:

A piece of rigging hardware used to attach a sling to a load.

Risk management:

The process of analyzing the work area and the lift before it is made to predict and account for any potential risks.

Shackle:

A coupling device used in an appropriate lifting apparatus to connect the rope to eye fittings, hooks, or other connectors.

Sheave:

A grooved pulley-wheel used to change the direction of a rope's pull.

Side pull:

The horizontal portion of a pull when the slings are not vertical.

Sling:

A form made of wire rope, alloy steel chain, metal mesh fabric, synthetic rope, synthetic webbing, or jacketed synthetic continuous loop fibers, with or without end fittings, used to handle loads.

Sling angle:

The angle at which a sling is pulled in relation to the load.

Sling legs:

The parts of the sling that extend from the attachment device around the object being lifted.

Sling reach:

The measurement from the master link of the sling, where it bears weight, to either the end fitting of the sling or the lowest point on the basket.

Sling stress:

The total amount of force exerted on a sling, including forces added due to sling angle.

Splice:

To join together.

Strand:

A group of wires wound or laid around a center wire or core. Strands are laid around a supporting core to form a rope.

Stress:

The intensity of force exerted by one part of an object on another, leading to changes in shape, strain, or separation of its parts.

Basic rigging terms

(Continued)

Tag line:

A rope that runs from the load to the ground. Riggers hold onto tag lines to prevent the load from swinging or spinning during the lift.

Tattle-tail:

A cord attached to the strands of an endless loop sling that protrudes from the jacket. A tattle-tail is used to determine if an endless sling has been stretched or overloaded.

Threaded shank:

The connecting end of a fastener, such as a bolt, with spiral grooves cut into it. The grooves are designed to mate with grooves cut into another object to join them together.

Warning yarn:

A component of the sling that indicates to the rigger whether the sling has suffered too much damage to be used.

Weight capacity:

The maximum amount of weight that a structure can safely support.

Wire rope:

A rope made from steel wires formed into strands and laid around a supporting core to form a complete rope. Sometimes referred to as a cable.

Rigging selection based on tension

Tension in pounds	Wire Rope Slings 6 x 19 IPS IWRC	Web Slings Nylon flat	Chain Slings Alloy G-8	Round Slings Polyester	Master Links Alloy	Screw Pin Anchor Shackles Carbon	Flat Shackles Alloy
4,000	1/2	2-9-2	5/16	EN60	1/2	1/2	1
6,000	5/8	2-9-2	3/8	EN90	5/8	5/8	1
8,000	3/4	2-9-3	1/2	EN90	3/4	3/4	1.5
12,000	7/8	2-9-5	1/2	EN150	1	7/8	1.5
16,000	1	2-9-6	5/8	EN180	1	1	2
20,000	1 1/8	2-9-4	3/4	EN240	1	1 1/4	3
24,000	1 1/4	2-9-6	3/4	EN360	1	1 1/4	3

To estimate **total capacity** of multi-leg sling assembly based on angle and number of legs in the assembly, multiply the following:

Load Factor (at right) x Tension rating (above).

90°	2.00	3.00
45°	1.41	2.12

Example: 1/2', 3-leg chain assembly at 45° = 2.12 x 12,000 = 25,440 pounds capacity.

Always refer to the rigging equipment manufacturers' specifications for proper applications and limitations.

Communication & hand signals

When lifting heavy equipment, it is important to communicate clearly. Make sure there is clear communication between the crane or derrick operator and other workers on site. Standard hand signals and communication protocols should be in place to enable safe operations.

A qualified signal person should communicate information to the equipment operator throughout the lift, allowing them to adapt to changes as they happen. Never assume the operator knows exactly what to do without direction. The main goal is to stay focused. Distractions lead to mistakes, and mistakes lead to injuries.





Learning the standard hand signals will enable

you to communicate the following to a crane or derrick operator:

- Which direction to **move**.
- When to **swing** and **lift** the boom.
- When to **hoist** and **lower** the load.
- When to **stop** or **hold** the lifting operations.

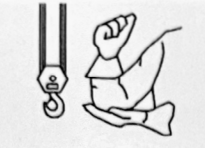
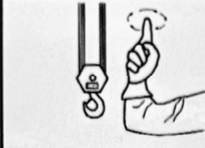
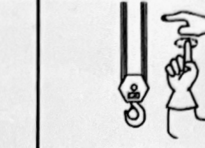
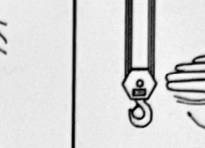
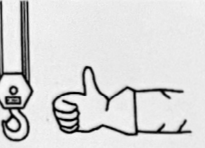
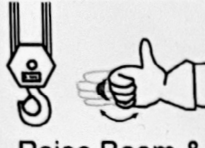
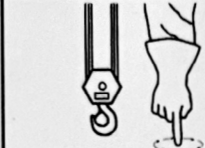
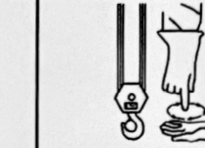
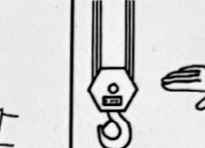
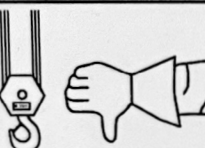
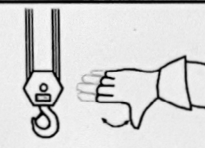
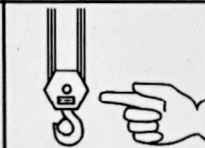
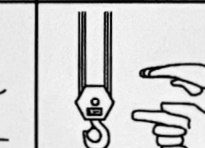
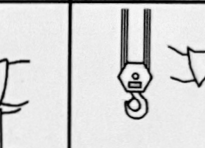
In addition to hand signals, radios are also used during lifting operations to maintain constant communication.

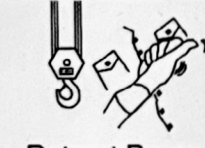
Hand Signals

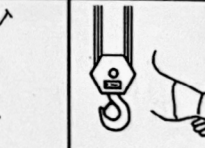
 Main Hoist	 Auxiliary Hoist	 Hoist	 Hoist Slowly	 Stop
 Raise Boom	 Raise Boom & Lower Load	 Lower	 Lower Slowly	 Emergency Stop
 Lower Boom	 Lower Boom & Raise Load	 Swing	 Swing Slowly	 Travel (Tracked Eqpt)
 Retract Boom 2 hands	 Retract Boom 1 hand	 Extend Boom 2 hands	 Extend Boom 1 hand	 Dog Everything

Lifting techniques for cranes

General lifting techniques

Understanding proper lifting techniques and best practices is critical to crane safety. While some of these steps have previously been discussed in this publication, review each of these processes again before lifting a load.

Before a lift is performed:

- **Conduct a visual inspection of the equipment.**
Ensure there is no visible damage, and the operator is familiar with all controls.
- **Inspect the site conditions.**
Avoid operating in adverse weather

conditions, such as high winds or rain, as this can increase the risk of accidents and injuries.

- **Check for potential hazards.**
Remove any objects that could obstruct the crane's movement, like wires and large rocks. Make sure the intended flight path to the landing is unobstructed.
- **Ensure the equipment and landing location will provide a stable area.**
If it is unstable, a timber crane mat may be needed to ensure the load is evenly distributed, and the crane is stable.



- **Ensure the outriggers, stabilizers, and other safety devices are positioned properly.**

The outriggers should be fully extended and at least one meter away from manholes and trenches to provide maximum stability and avoid accidents. Remember that cranes with a higher load radius are more likely to tip over during operation.

- **Know the weight of the load.**
Always lift to the owner manual's stated safe working load and avoid overloading the crane or boom truck, as this can result in equipment failure and accidents.

- **Barricade the swinging radius.**
The swinging radius of the crane should be barricaded, and only trained and certified riggers should be allowed in the area. Use signage to mark off the work zone so workers do not put themselves in danger. Under no circumstances should anyone be allowed under the suspended load, even if they are a rigger.

- **Check the rigging.**
Make sure the slings and rigging have a sufficient rated capacity for the load and rigging method. Does it provide control without damaging the sling?

- **Check the load's center of gravity.**
Ensure **the crane hook and rigging are plumb over the load's center of gravity.** On overhead cranes, make sure the trolley and bridge are aligned with the hoist rope over the load's center of gravity.

- **Identify the tagline or push/pull stick attachment point on the load.**

Ensure an assistant is prepared and informed about the tagline, the push/pull stick control, the travel path, and the lift sequence. A minimum of two tag lines should be used to control the swinging of the load.

- **Wear appropriate personal protective equipment (PPE).**
Riggers should wear bright jackets or other appropriate PPE for the worksite and task.

When performing a lift



Practice proper communication protocols.

Inform teammates of the planned movement. A qualified and competent operator will communicate that it is time to perform the load-moving task. Only the rigger should give signals to the crane operators. Miscommunication or misunderstanding of signals can result in accidents and injuries.



Keep loads as low to the ground as is reasonably safe.

Ensure the weight is distributed evenly and avoid sudden movements or jerks that could cause the load to swing or shift.



Keep at least one set of eyes on the load at all times.

After a lift and when parking the crane, use these tips:

- Secure the load.
- Raise all hooks to an intermediate position.
- Properly stow the crane, stabilizers, winches, and any other moving parts in an approved designated location.
- Ensure all controls are in the "OFF" position.
- Visually check the area and crane before leaving.

If/Then Guidelines

IF the boom or crane cab swings to one side when raising or lowering the load, **THEN** re-level the crane.

IF using the jib to make a lift, **THEN** check to see if the crane is level; ensure the lift is made using outriggers, not tires; confirm the capacity on the jib chart and also the main chart making sure to never exceed either chart; and refer to the boom/jib angle information, not the radius.

IF outriggers settle into the ground while making a lift, **THEN** cease all movements and slowly lower the load to the ground; increase the outrigger footprint with blocking; re-level the crane and re-measure the radius; check the load chart for radius and boom length; and proceed if the capacity is confirmed.

IF the hydraulic functions are jerky, **THEN** use more engine RPM; check the hydraulic level; and check lubrication points.

General lifting techniques using a telescoping boom

- Use the shortest boom length needed for the head and hoist height, but long enough to handle the longest radius: the pickup, swing, or set-down point.
- Lift the load in a controlled manner.
- Raise the boom and lower the load line to bring the load closer to the crane.
- Swing the crane to align properly for the set-down point.
- Lower the boom and raise the load line.
- Lower the load and make any necessary adjustments for placement.
- Discuss the procedure with the signaler and rigging crew to ensure everyone knows how the load will be lifted and placed.
- Always follow signals as the signaler has a better view from the ground.
- Remember to pay attention to the boom length and hoist height to avoid two-blocking.

General two-crane lift guidelines

- Review the load movement to determine if it can be accomplished with one crane. If not, proceed with the following two-crane guidelines.

(Continued)

General two-crane lift guidelines (Continued)

- Do not exceed 75% of either crane's load capacity chart for their maximum intended radius. (Hoist lines can get out of plumb.)
- When turning a load, predetermine the maximum weight expected for each crane.
- Keep the load level to avoid crane overload (if no turning is required).
- Establish a signal system and lift procedure.
- Keep the hoist lines plumb to avoid sideloading booms.
- Perform a "dry run."
- Complete a **Critical Lift Plan**:
 - Confirm the load description, structural integrity, weight, and pick points.
 - Confirm the weight of all handling devices, including blocks, lifting beams, rigging, jib, and wire rope.
 - Know the maximum boom length, angle, and radius required at pick-up, swing, or set-down points over the side, front, or rear.
 - Confirm the maximum load on the crane and the percentage of the crane's rated capacity at the greatest radius.
- Confirm that the hoist rope of the crane is threaded or passes through enough sections or parts of the line to ensure proper lifting and support of the load.
- Confirm all rigging techniques, proper sling loading, and handling of device capacities.
- Ensure proper crane setup, including that it is on a level, solid foundation with proper outrigger blocking, and avoids high voltage hazards and obstructions for the lift or swing area.
- If travel with a load is required, use a pick-and-carry crane chart and confirm the travel path.
- Review the drawings and calculations for the load and rigging.
- Confirm the following:
 - » The crane and rigging are inspected.
 - » The crane is properly set-up.
 - » The swing area, hoist height, and head height are accurate.

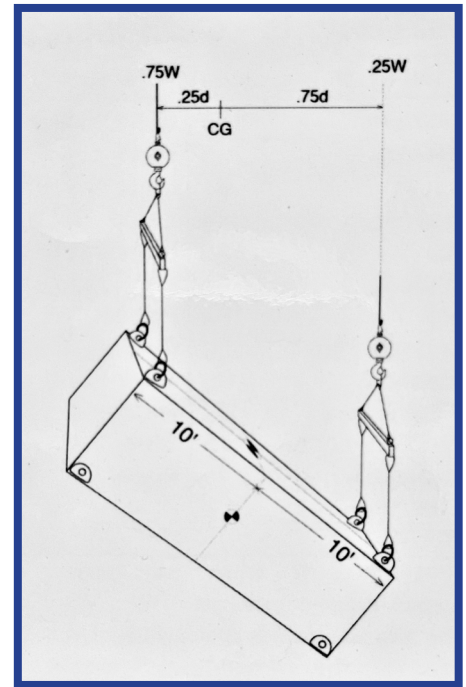

Rules for slinging cargo

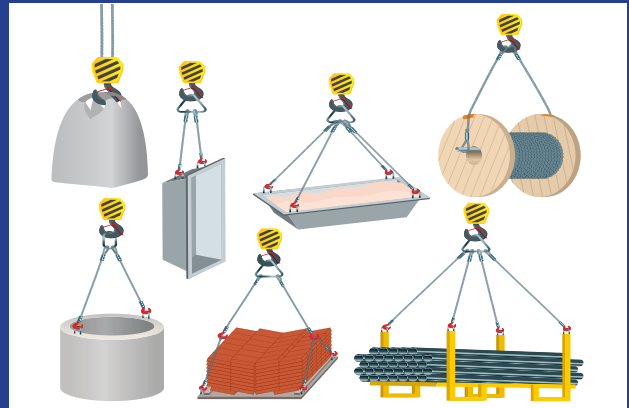
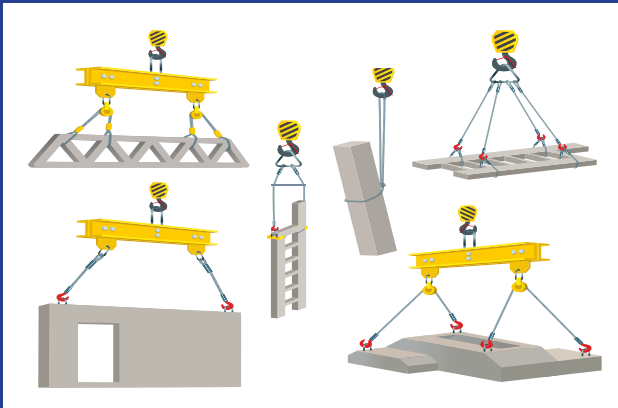
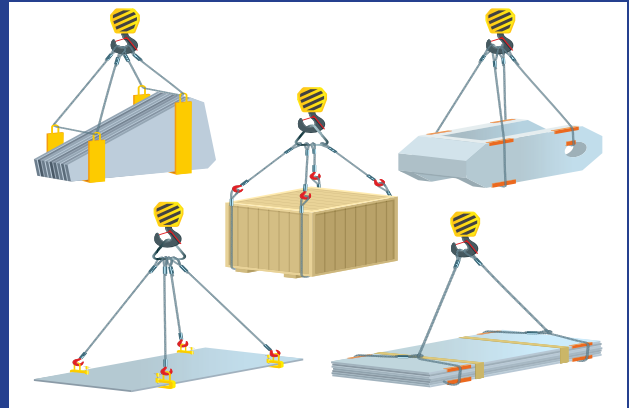
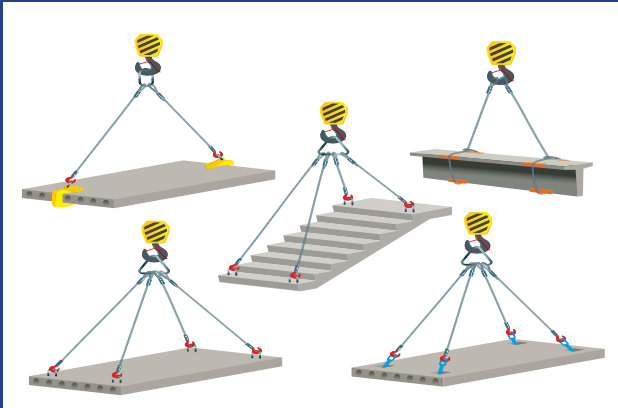

- » There is a correct crane counterweight.
- » The crane operator is trained and qualified.
- » Riggers are trained and qualified.
- » A signal system and radio communication are in place.
- » Wind, temperature, and taglines are monitored.
- » Safety spotters are on hand. Steps for traffic control have been taken.
- » Know if a crane load test/rigging proof test is required?
- » A pre-lift meeting has occurred with all personnel.

- » The site is controlled.
- » Approval signatures have been obtained from the lift director, site supervisor, crane operator, lead rigger, and signaler.

Emergency procedures

Having emergency procedures in place is crucial for responding to unforeseen circumstances or equipment failures. A well-defined plan should be established, and all personnel should be aware of their roles and responsibilities during emergencies. It should include contact numbers for emergency services, response and evacuation procedures, and medical treatment. All workers must participate in emergency procedure training.

HAZARDS

According to the [Center for Protection of Workers' Rights \(CPWR\)](#), one crane accident occurs for every 10,000 hours of use in the United States. The following section reviews some of the most common hazards associated with using cranes in construction, and the safety measures needed to mitigate these risks. Possible hazards include:

- Risk of load instability and tipping.
- Overload and collapse.
- Contact with power lines.
- Adverse weather.
- Falling objects.
- Entanglement.
- Pinch points.
- Dropped loads.
- Collisions.

Risk of load instability and tipping

Crane tipping accidents can be dangerous and costly. Understanding the primary causes of crane tipping is crucial for preventing such incidents. Here are some key points to keep in mind:

- **Load imbalance.**
The main reason cranes tip is due to an imbalance in the load being lifted. If the load is too heavy or not properly secured, it can cause the crane to become unstable and tip. Always ensure that the load is within the crane's lifting capacity and properly secured.
- **Uneven ground.**
Uneven or unstable ground can contribute to crane tipping. It is important to assess the ground

conditions and make necessary adjustments to ensure a stable lift.

- **Malfunction and improper operation.**
Malfunctions in crane equipment can lead to instability. Operators must be watchful, conduct regular inspections, and take immediate action to prevent injuries when malfunctions occur. Always ensure all personnel are well trained to prevent improper operations or handling of the crane, which can increase the risks of tipping.
- **Adverse weather conditions.**
Strong winds can significantly impact the stability of a crane. It is essential to consider weather conditions and follow the manufacturer's guidelines regarding the maximum allowable wind speeds for safe lifting operations.
- **Recognize the signs of instability during crane operations.**
Sudden movements, shaking, or vibrations can indicate potential tipping hazards. If any of these signs appear, stop and evacuate the situation to ensure everyone's safety. Are outriggers placed correctly? Were the weight capacities calculated properly? Are the brakes working effectively (especially after making multiple heavy lifts from one direction?)

By understanding the risks and using the proper safety protocols, the chances of crane tipping accidents are minimized.

Conditions leading to loss of a load or crane

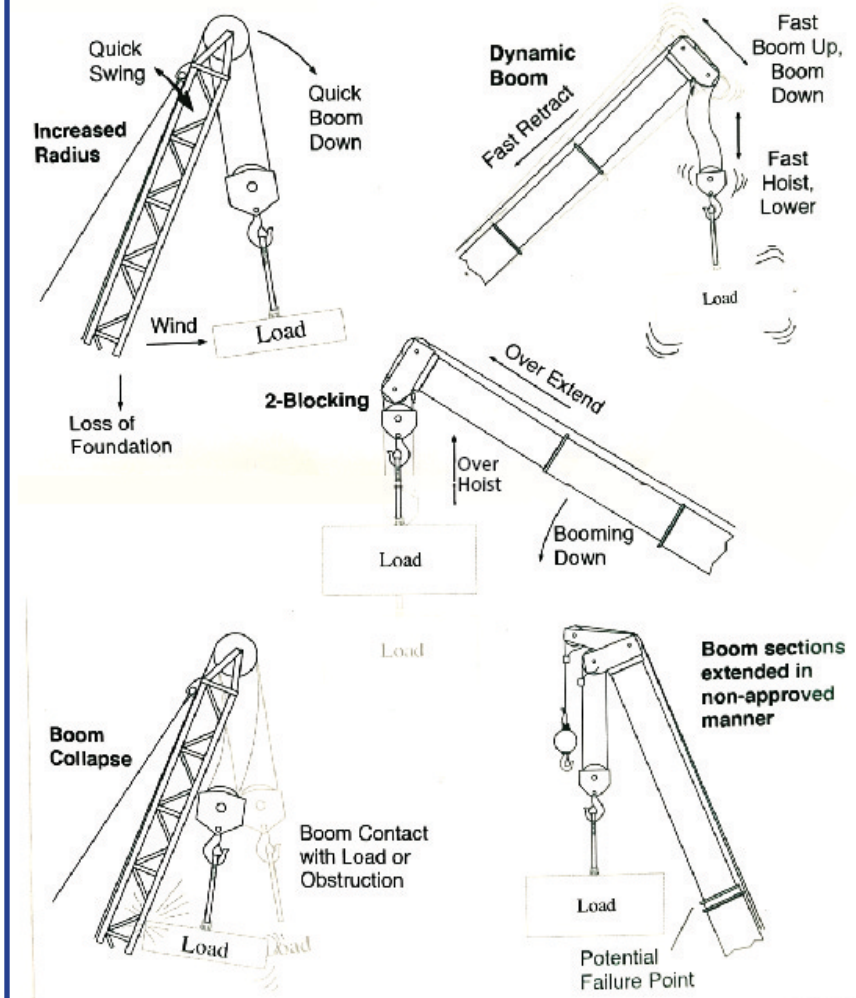

If/Then Guideline

IF the crane starts to tip during a lift,

THEN quickly decrease the radius by retracting the boom and lowering the load line.

- **Counterbalance and outrigging.** Use proper counterweights and fully-extended outriggers to balance the load. Surpassing the load limitations can cause the boom to collapse or the equipment to tip.
- **Proper load placement.** Correctly placing the load is vital. Ensure that all loads are centered and use slings to secure them. If the load is prone to rotation or swinging, taglines should be used to control its movement.

Overload and collapse

Overloading, which can lead to collapse, is one of the biggest risks in operating cranes and derricks that lift heavy loads. These tips will help ensure safety:

- **Stick to load limits.** Falling, collapsing, or overturning accidents often occur when load limits are exceeded, or loading is done incorrectly. It is crucial to follow the maximum load capacity specified and never exceed it. These weight limits are in place to prevent collapse and ensure safe operation.

- **Trained operators.** Overloading a crane or derrick can lead to permanent breakdowns. It is crucial to have trained operators in charge of running cranes and derricks on construction sites to prevent exceeding the equipment's capacity.
- **Falling loads.** Falling loads pose a significant hazard when using overhead cranes. The majority of dropped loads are caused by wire rope failures – either by overstressing or rope damage.

This can cause injuries, fatalities, and extensive damage to structures and property. It is vital to inspect wire rope and rigging regularly to prevent this dangerous and costly problem.

Remember, proper training, adherence to load guidelines, and proper equipment inspections are key to preventing crane and derrick overload and collapse.

Contact with power lines

Working near live power lines can pose serious risks to equipment operators and other workers on the job site. Contact with overhead power lines is a leading cause of worksite fatalities and injuries. It is important to prioritize safety and take necessary precautions when working with overhead cranes, derricks, and electric cables.

- **Provide training on the hazards of working near power lines.** Employee training is important to ensure their safety. Training should include:

- o Information about the danger of electrocution.
- o The importance to the operator's safety of remaining inside the cab except where there is danger of fire, explosion, or other emergency that requires leaving the cab.
- o The safest means of evacuating from equipment that may be energized.
- o The danger of a possible energized zone around the equipment.
- o The need for crew in the area to avoid approaching or touching energized equipment and the load.
- o Safe clearance distance from power lines.
- o The limitations of safety devices, if used.
- o How to properly ground equipment and the limitations of grounding.

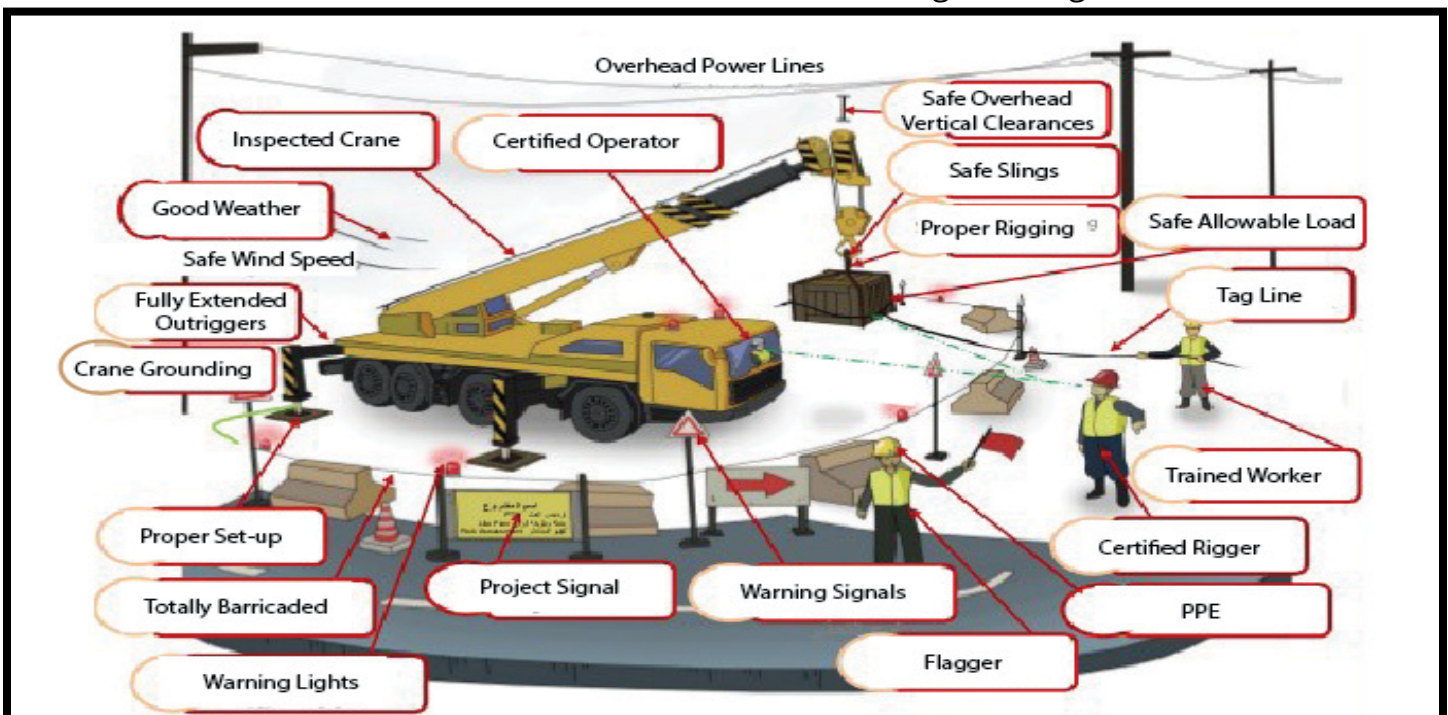

- **Use care when assembling or disassembling a crane or derrick near a power line.**

When assembling or disassembling equipment near a power line, the previous precautions apply. Also, when moving equipment, the minimum clearance distances must be maintained.

There are limited exceptions to the mandatory minimum clearance when minimum distance is impossible. In these cases, more precautions are required due to the danger. First, determine if alternative methods can maintain the required distance and consult the utility for deenergizing, grounding, or relocating the line. If all other methods are unavailable, use these precautions for operating closer to power lines than the minimum distance:

- **Determine an absolute minimum clearance.**
Have a qualified person determine the minimum clearance distance based on on-site conditions.
- **Hold a planning meeting.**
Meet with the utility owner or operator to determine procedures to prevent electrical contact.
- **Use protective features.**
 - o Make any automatic reclosing features inoperative if present.
 - o Use a dedicated spotter in continuous contact with the operator.
 - o Erect an elevated warning line or barricade with high-visibility markings.
 - o Install an insulating link or device between the load line and load.
 - o Insulate or guard employees from equipment, load line, and load.

- o Use nonconductive rigging and tag lines.
- o Use a device to limit range of movement.
- o Erect barricades to prevent unauthorized personnel from entering the work area.
- o Prohibit workers from touching the load line above the insulating link or device and crane.
- o Limit personnel to essential workers.
- o Properly ground the equipment.
- o Install insulating line hose or cover-up.

- **Appoint a project director.**
Identify a person with the authority to ensure safety and stop work if necessary.
- **Reconsider your plan if a problem arises.**
If procedures are inadequate, stop work and develop new procedures or deenergize or relocate the power line.

For more information on working near power lines safely, always review the standards for your unique worksite situation:

- **1926.1407 - Power line safety (up to 350 kV)--assembly and disassembly.**
- **1926.1408 - Power line safety (up to 350 kV)--equipment operations.**
- **1926.1409 - Power line safety (over 350 kV).**
- **1926.1410 - Power line safety (all voltages)--equipment operations closer than the Table A zone.**

Adverse weather

Operating a crane or derrick safely requires being prepared for changes in weather conditions. Inclement weather can pose risks and potentially lead to accidents. Here are some weather conditions that can impair lifting operations:

- **Strong winds.**
Strong winds can be a major hazard for crane and derrick operations. They can cause tipovers and serious or even fatal injuries. It is important to be aware that wind speeds increase at higher altitudes. Operators should be cautious and prepared for sudden gusts of wind.
- **Rain.**
Heavy rain can have adverse effects on crane and derrick operations. It can damage equipment and slow down vital components. Operators should take precautions to protect the crane or derrick and ensure that it continues to function properly during rainy conditions.
- **Lightning.**
Cranes and derricks are particularly vulnerable to lightning strikes. A bolt of lightning can cause significant damage to the machinery and pose a safety risk. Operators should halt operations during a lightning storm and wait until it is safe before resuming operations. It is crucial to ensure that the crane or derrick is safe to operate once the lightning has ended.

Crane and derrick operators should be prepared to adapt to changing weather conditions to ensure the well-being of everyone on the job site.



Falling objects

When working with a crane or derrick, there is always a risk of falling objects. This can occur if a equipment malfunctions or if the chains and hooks holding the load become detached. Falling materials can be extremely dangerous, potentially causing harm to workers and significant damage to property and structures.

To prevent accidents caused by falling objects, follow these safety measures:

- **Use barriers and netting.**
Use barriers and netting to catch falling objects before they can harm anyone.
- **Install an anti-two-blocking falling system.**
A two-blocking accident occurs when the hoisting hook comes in contact with its boom tip, putting extra stress on the hoist line. This is a dangerous scenario that can cause the hoist to snap and the load to drop, wreaking havoc on the work

site. Two-blocking can be prevented by installing a safety device called an anti-two-blocking system. This is an electrical device with a built-in sensor that helps the equipment operator prevent two-blocking incidents. Neglecting this precaution can lead to workplace injuries that may have severe consequences for your workers and your business.

By making safety a priority and creating these preventive measures, you can minimize the risk of falling objects during lifting operations.

Entanglement

Death or serious injury may result if ropes get entangled with the fixed structure on the crane or derrick. This may include entanglement of clothing, hair, beards, hands, or feet in moving equipment, such as rigging parts. Entrapment or crushing between moving or rotating structures can also occur. It is important to identify potential entanglement points to decrease the risks. Always remove, disconnect, and stow ropes securely.

Pinch points

When cranes or derricks are in operation, they need to move to transport loads. Unfortunately,

this movement can create pinch points or crush points that pose a serious risk of injury.

What makes this hazard even more dangerous is that the area directly around the crane or derrick is typically not within the operator's line of sight. This means that workers can easily find themselves in harm's way without realizing it.

Pinch point injuries can occur at any time during the movement of materials, equipment, or loads:

- **Between the sling and the load.**
- **Between the load and a fixed object.**
- **Between the load and its resting point.**

To stay safe around moving equipment and avoid pinch-point accidents, it is crucial to:

- **Stay alert.**
Be vigilant and aware of your surroundings. Pay attention to potential pinch points and avoid placing yourself in hazardous positions.
- **Communicate.**
Maintain clear communication with the equipment operator and other workers involved in the lifting operation. Ensure everyone is aware of the potential pinch points and takes necessary precautions.
- **Use proper equipment.**
Make sure you have the appropriate PPE for the job, including gloves and safety gear that can help protect against pinch-point injuries.





- **Training and education.**
Receive proper training on crane or derrick safety and pinch point awareness. Understand the risks associated with moving cranes and derricks and how to mitigate these risks effectively.

By being mindful of pinch points and following these safety measures, the risk of injuries can be reduced.

Dropped loads

When a crane or derrick drops its load, everything beneath it, including people, structures, and vehicles, can be crushed. That is why it is crucial to never work directly under a load, even if you are wearing PPE.

Crane and derrick operators often cannot see the load because it is outside their line of sight. Placing cameras on the structures helps operators expand their field of vision and have a clear view of every part of the lift, including the loading process. These cameras feed live footage to a monitor in a location that allows the operator to directly observe the load. The in-cab monitor on cranes enables the crane operator to ensure that riggers and spotters properly secure the load.

Crane and derrick personnel need to be constantly aware of:

- **Slipping.**
Inadequately secured loads can easily slip. It is important that all loads are properly secured before lifting operations begin.



- **Mechanical malfunction.**
Regular inspections, repairs, and maintenance performed by qualified individuals greatly reduce the risk of equipment failure. Prioritizing these measures is crucial for safe crane operations.
- **Human error.**
Providing comprehensive training to all employees ensures they have the skills and knowledge to perform their jobs effectively and responsibly. This includes proper crane and derrick load management.

By addressing these factors and implementing safety measures, we can significantly reduce the risk of dropped loads.

Collisions

Collisions can have severe consequences, leading to injuries, property damage, and costly disruptions. It is important to be aware of the common causes of these accidents to prevent them effectively:

- **Lack of communication.**
Poor communication among workers involved in crane operations can result in collisions. When there is a lack of clear instructions, coordination, or signaling, it increases the risk of two cranes colliding or a crane colliding with other objects or structures.

(Continued)

- **Limited visibility.**
Limited visibility is a significant challenge for crane and derrick operators. They may have blind spots or restricted views due to the equipment's design or the surrounding environment. This can make it difficult to see obstacles, other equipment, or workers, leading to collisions.
- **Mechanical failure.**
Crane malfunctions or mechanical failures can lead to collisions. Issues with the crane's controls, hydraulics, brakes, or other components can cause unexpected movements or loss of control, resulting in collisions with objects or other cranes.
- **Improper maintenance.**
Neglecting regular maintenance and inspections of cranes can lead to equipment failure and the increased likelihood of collisions. Worn-out parts, faulty mechanisms, or inadequate repairs can compromise the crane's performance and safety.
- **External Factors.**
External factors such as adverse weather conditions, uneven terrain, or obstacles in the work area can contribute to crane collisions. These factors can affect the crane's stability, maneuverability, or visibility, making collisions more likely.

By addressing these causes and implementing preventive measures, the risk of crane collisions can be reduced.

Other safety procedures

Many safety procedures, such as lockout/tagout, fall protection, and hazard

communications, apply to cranes. By addressing these common safety topics in a unified training program, employers can ensure consistent safety practices across different equipment types and streamline their safety training efforts.

Lockout/tagout

Lockout/tagout policies and procedures are crucial for ensuring the safety of workers during crane repair and other equipment servicing. The main goal is to completely lockout and dissipate all energy sources, confirming a zero-energy state, before any maintenance work begins. It is not just electricity that needs to be locked out, but also other hazardous energy sources such as:

- **Steam.**
Steam systems must be properly locked out to prevent accidental releases of high-pressure steam, which can cause severe burns or injuries.



- **Hydraulic pressure.**
Hydraulic systems can store significant pressure that can lead to sudden movements or releases of energy. Locking out hydraulic systems is essential to prevent accidents.
- **Heat and thermal energy.**
Equipment that generates heat or thermal energy should be properly locked out to avoid burns or exposure to extreme temperatures.
- **Air pressure.**
Compressed air systems can pose risks if not properly locked out. Sudden releases of air pressure can cause equipment to move or create hazardous conditions.
- **Mechanical energy.**
Mechanical systems, including moving parts and rotating machinery, should be locked out to prevent accidental activation or movement that can cause injuries.
- **Kinetic energy.**
Kinetic energy, often overlooked, can be dangerous. For example, the blades of a fan may continue to move even after power is shut off. Locking out such equipment is necessary to avoid potential harm.
- **Gravity.**
Gravity poses a risk during crane and derrick repair. The force of gravity can cause heavy hooks to fall or start the motor turning unexpectedly. Technicians can be endangered if they get caught inside the gear case, drum, motor, coupling, or shaft. To prevent this, bring the hook to the ground and locked out.

- **Hazardous chemicals.**
While not an energy source, hazardous chemicals also require lockout procedures to prevent harmful exposure. This includes locking out systems that contain chemicals to prevent direct exposure or exposure to harmful fumes.

Fall protection.

The safety harness protects personnel from falls when working at heights, such as on cranes and derricks. [OSHA requires](#) the use of a safety harness and fall protection measures when working at heights of 6 feet or more above a lower level.

Make sure to inspect your safety harness before each use. Look for worn or frayed parts and any signs of damage, including cracks in the plastic coating and broken clips. If you notice anything risky about your harness, stop using it immediately and have it replaced. For more information, see DWC's [Fall Protection for the Construction Industry Workplace Program](#).

Hazard communication.

OSHA's hazard communication rules apply to all workplaces where workers may be exposed to hazardous chemicals during routine use or in a foreseeable emergency. A hazardous chemical is defined as any chemical that is classified as a physical hazard, a health hazard, an [asphyxiant](#), combustible dust, [pyrophoric gas](#), or a hazard not otherwise classified. For further details about the definitions of chemical hazards, please look at OSHA's Chemical Hazards and Toxic Substances [webpage](#).

PPE.

Never step onto a heavy equipment job site without wearing the proper PPE, which often include a hard hat, safety vest, boots, safety glasses, and gloves.

APPENDIX A:

General Crane Inspection Checklists

Inspections should be conducted throughout the project at various stages, including before each lift, to ensure that equipment, rigging gear, and other components are in proper working condition and meet safety standards. Regular inspections help identify any defects or issues that may compromise the safety of the operation and allow for timely maintenance or repairs.

Initial Inspection Checklist (Perform to new and altered cranes before initial use.)	
<input type="checkbox"/>	Review all new, altered, or used cranes .
<input type="checkbox"/>	Replace or fix damaged crane parts or cranes.
<input type="checkbox"/>	Check the following crane functions (as applicable): Hoisting and lowering. Trolley travel. Bridge travel. Limit switches. Locking and safety devices.
<input type="checkbox"/>	Perform a load test.

Frequent Inspection Checklist (Perform daily to monthly or during operations hours for any defects.)	
<input type="checkbox"/>	Check all mechanisms for any malfunctions that may interfere with the machine during operation.
<input type="checkbox"/>	Check for any deterioration or leaks in lines, tanks, valves, and drain pumps of the crane.
<input type="checkbox"/>	Check the hooks for any deformation or damages.
<input type="checkbox"/>	Check hoist chains, including end connections, for any damages or twists.
<input type="checkbox"/>	Review all operating mechanisms for any excessive wear or damages.
<input type="checkbox"/>	Rope reeving should follow the manufacturer's recommendations.
<input type="checkbox"/>	Perform a monthly inspection with a certification record.

Periodic Inspection Checklist

(Perform every 1 to 12 months.)

<input type="checkbox"/>	Check any deformed, cracked, or corroded parts.
<input type="checkbox"/>	Check any loose bolts or rivets.
<input type="checkbox"/>	Check if the sheaves and drums are cracked or worn.
<input type="checkbox"/>	Check all pins, bearings, shafts, gears, rollers, locking, or clamping devices that are cracked, deformed, or damaged.
<input type="checkbox"/>	Check the brake system parts, linings, pawls, and ratchets for any damages or excessive wear.
<input type="checkbox"/>	Check load, wind, and other indicators over their full range.
<input type="checkbox"/>	Check the crane's fuel system for any improper performance.
<input type="checkbox"/>	Check the chain drive sprockets and chain stretch for any damages or excessive wear.
<input type="checkbox"/>	Check the electrical apparatus for any signs of deterioration.

APPENDIX B:

Overhead Crane Pre-Lift Inspection Checklist

Overhead Crane Pre-Lift Inspection Checklist	
<input type="checkbox"/>	Operator – qualified and certified.
<input type="checkbox"/>	Main power disconnect -- Labeled and easily accessible.
<input type="checkbox"/>	Crane remote, pendant, or cab controls – Labeled. Return to neutral when released. Warning tag present (except on cab-operated cranes). No exposure to energized components. Workable height. Tension restraint (pendant control only).
<input type="checkbox"/>	Cabs – Fire extinguisher (with valid inspection). Cab is accessible. Proper housekeeping.
<input type="checkbox"/>	Upper limit switch – tested by “inching” into it.
<input type="checkbox"/>	Warning system – present for cab-operated machines.
<input type="checkbox"/>	Columns, runways, and rails – ground inspection for gross deformity or missing components.
<input type="checkbox"/>	Festoons, conductors, and collectors – Festoons – check for hang-ups or bare wires. Conductors – anchored properly and straight. Collectors – riding properly along conductors.
<input type="checkbox"/>	Bridge structure – Markings on both sides and visible from the floor. Ground inspection for gross deformity. Proper travel – no racking, slippage, or excessive vibration. Bumper and stop alignment.
<input type="checkbox"/>	Trolley – Ground inspection for gross deformity or missing components. Bumper and stop alignment. Proper travel – no racking, slippage, or excessive vibration.

(Continued)

Overhead Crane Pre-Lift Inspection Checklist

(Continued)

<input type="checkbox"/>	<p>Drums –</p> <p>Ground inspection for gross deformity or missing components. Two-wraps minimum. Wire rope in proper grooves.</p>
<input type="checkbox"/>	<p>Blocks –</p> <p>Proper capacity markings. Pins and guards are present.</p>
<input type="checkbox"/>	<p>Hooks (daily visual) – No deformation or cracks.</p>
<input type="checkbox"/>	<p>Sheaves –</p> <p>Smooth and free of defects that could damage wire rope. Rotates smoothly without wobble. Has lubrication points.</p>
<input type="checkbox"/>	<p>Wire rope (daily visual) –</p> <p>No distortion of the rope. No general corrosion. No broken or cut strands.</p>
<input type="checkbox"/>	<p>Hoisting chain (daily visual including end connections, if applicable) –</p> <p>No excessive wear. No twists. No distorted links interfering with proper function or stretch beyond manufacturers' recommendations.</p>
<input type="checkbox"/>	<p>Adequate lighting.</p>

APPENDIX C:

Wire Rope Pre-Shift Inspection Checklist

Wire ropes must be inspected by a competent person before each shift. Wire ropes must be removed from service if there is any of the following:

Wire Rope Pre-Shift Inspection Checklist		
Yes	No	Wire ropes must be removed from service if there is any of the following:
<input type="checkbox"/>	<input type="checkbox"/>	<p>Are there any visible defects? If a wire rope has visible defects that could affect its safe operation, it must be removed from use immediately. Examples of visible defects include broken wires, corrosion, distortion, or other damage that could compromise the integrity of the rope.</p>
<input type="checkbox"/>	<input type="checkbox"/>	<p>Is there a reduction in the rope diameter? If the diameter of the wire rope is reduced by 1/32 inch (0.8 mm) or more due to wear, it must be taken out of service. This reduction in diameter can be measured by comparing the diameter of the rope to its original size or by using a caliper.</p>
<input type="checkbox"/>	<input type="checkbox"/>	<p>Is there any loss of strength? If the wire rope has lost more than 10% of its nominal strength due to wear, corrosion, or other factors, it should be removed from service. This loss of strength can be determined through testing or by consulting the manufacturer's specifications.</p>
<input type="checkbox"/>	<input type="checkbox"/>	<p>Is there excessive wear? If the wire rope shows signs of excessive wear, such as flattened or distorted strands, it should be taken out of service. Excessive wear can weaken the rope and increase the risk of failure.</p>
<input type="checkbox"/>	<input type="checkbox"/>	<p>Has the rope reached its manufacturer's recommended service life? If the manufacturer of the wire rope specifies a maximum service life or recommends a retirement criteria, those guidelines should be followed. It is important to consult the manufacturer's documentation for specific information regarding the retirement of wire ropes.</p>

APPENDIX D:

Hoist Safety Inspection Checklist

Hoist Safety Inspection Checklist		
Yes	No	
<input type="checkbox"/>	<input type="checkbox"/>	The crane is operational and not tagged out of service at the crane controller, hook, or main disconnect box.
<input type="checkbox"/>	<input type="checkbox"/>	All control functions are operational.
<input type="checkbox"/>	<input type="checkbox"/>	Slack has been slowly removed from the rigging while hoisting.
<input type="checkbox"/>	<input type="checkbox"/>	The minimum wraps of rope are wrapped on the hoist drum.
<input type="checkbox"/>	<input type="checkbox"/>	Operation is smooth while hoisting, lowering, bridging, and trolleying.
<input type="checkbox"/>	<input type="checkbox"/>	While hoisting a high-capacity load, the operator stops to ensure break integrity, then proceeds.
<input type="checkbox"/>	<input type="checkbox"/>	The operator remains at the controls while load is suspended.
<input type="checkbox"/>	<input type="checkbox"/>	The operator stops the load movement if the walking path includes ramps or stairs and does not continue until the crane is repositioned.
<input type="checkbox"/>	<input type="checkbox"/>	The load swing is minimized by using crane controls, taglines, or push/pull sticks.
<input type="checkbox"/>	<input type="checkbox"/>	The operator never hoists or passes a load over personnel.
<input type="checkbox"/>	<input type="checkbox"/>	Crane-to-crane contact is avoided.
<input type="checkbox"/>	<input type="checkbox"/>	Operations proceed if crane signals are being used and stop if there is a need for clarification.
<input type="checkbox"/>	<input type="checkbox"/>	The operator and tagline/sign person maintain low risk positions around the load.
<input type="checkbox"/>	<input type="checkbox"/>	Pinch/crush areas between the load and surrounding obstructions are avoided.
<input type="checkbox"/>	<input type="checkbox"/>	All crane controllers are moved to the off position if a power outage occurs.
<input type="checkbox"/>	<input type="checkbox"/>	Upper or lower limit switches are NOT used for an operation stop.

APPENDIX E:

Suspended Personal Platform Inspection Checklist

Suspended Personal Platform Inspection Checklist		
Yes	No	
<input type="checkbox"/>	<input type="checkbox"/>	<p>SPP is justified under 29 CFR 1926.1431 and ASME B30.23.</p> <p>Conventional scaffolding or other means of access are not feasible or would present a greater hazard.</p> <p>Work being performed from the platform is temporary and does not involve prolonged exposure.</p>
<input type="checkbox"/>	<input type="checkbox"/>	Crane, rigging, and platform are inspected.
<input type="checkbox"/>	<input type="checkbox"/>	Personnel, tools, and materials are within SPP weight capacity.
<input type="checkbox"/>	<input type="checkbox"/>	Safety equipment, radios, and taglines are present, accurate, and functional.
<input type="checkbox"/>	<input type="checkbox"/>	Crane foundation is secure and free of obstructions.
<input type="checkbox"/>	<input type="checkbox"/>	Weather is not a factor, and the winds are less than 20 mph.
<input type="checkbox"/>	<input type="checkbox"/>	Indicators (no-free-fall, A-2-B, boom length, and angle) are function properly.
<input type="checkbox"/>	<input type="checkbox"/>	Self-locking hooks, safety hooks, or positive-locking hooks function properly.
<input type="checkbox"/>	<input type="checkbox"/>	Weight of the SPP & load have been calculated.
<input type="checkbox"/>	<input type="checkbox"/>	Load does not exceed 50% of the hoist line capacity and is within the load chart limit at working radius.
<input type="checkbox"/>	<input type="checkbox"/>	Crane is level to within 1% grade and on firm ground.
<input type="checkbox"/>	<input type="checkbox"/>	Outriggers (or stabilizers) are fully extended.
<input type="checkbox"/>	<input type="checkbox"/>	Pre-lift meeting involves all personnel.
<input type="checkbox"/>	<input type="checkbox"/>	A proof test of 125% suspended for 5 minutes is done at each worksite (or completed concurrently with the trial test lift.)
<input type="checkbox"/>	<input type="checkbox"/>	Secure tools, materials, and complete a test lift.
<input type="checkbox"/>	<input type="checkbox"/>	Review lift procedures if test lift succeeds.

(Continued)

Suspended Personal Platform Inspection Checklist

(Continued)

Yes	No	
<input type="checkbox"/>	<input type="checkbox"/>	Remove test weights and complete a final inspection of the SPP.
<input type="checkbox"/>	<input type="checkbox"/>	Inspect and install fall protection equipment.
<input type="checkbox"/>	<input type="checkbox"/>	Hoist lines are without kinks and twists.
<input type="checkbox"/>	<input type="checkbox"/>	Hood is centered over the SPP.
<input type="checkbox"/>	<input type="checkbox"/>	Load personnel and lift the SPP 6". Re-inspect the SPP.
<input type="checkbox"/>	<input type="checkbox"/>	All body parts are inside the SPP.
<input type="checkbox"/>	<input type="checkbox"/>	No other loads on the hook.
<input type="checkbox"/>	<input type="checkbox"/>	All movements are easy and slow.
<input type="checkbox"/>	<input type="checkbox"/>	Move SPP to the worksite according to the trial procedure.
<input type="checkbox"/>	<input type="checkbox"/>	Crane operator sets brakes and stays in cab, attentive.
<input type="checkbox"/>	<input type="checkbox"/>	Ground personnel guard for traffic and obstructions.
<input type="checkbox"/>	<input type="checkbox"/>	May or may not secure SPP to worksite via tie-off.
<input type="checkbox"/>	<input type="checkbox"/>	Perform work, never leaning out of the SPP.
<input type="checkbox"/>	<input type="checkbox"/>	Remove tie-off, if necessary.
<input type="checkbox"/>	<input type="checkbox"/>	Return SPP to the ground per safe procedures.
<input type="checkbox"/>	<input type="checkbox"/>	Reinspect all equipment.
<input type="checkbox"/>	<input type="checkbox"/>	Conduct a post-lift review with all personnel.

APPENDIX F:

Helicopter Crane Critical Lift Operations Checklist

General Requirements for Project Managers		
Yes	No	
<input type="checkbox"/>	<input type="checkbox"/>	Obtain all required permits, as necessary.
<input type="checkbox"/>	<input type="checkbox"/>	Obtain FAA airspace clearance and adhere to all FAA and local restrictions.
<input type="checkbox"/>	<input type="checkbox"/>	Verify that landing zones or areas can support loads.
General Requirements for Contractors		
<input type="checkbox"/>	<input type="checkbox"/>	Submit valid certificate of insurance (COI) for all contractors and subcontractors involved.
<input type="checkbox"/>	<input type="checkbox"/>	Submit valid helicopter inspection report and certification that do not indicate any deficiencies.
<input type="checkbox"/>	<input type="checkbox"/>	Submit valid helicopter pilot license and certification for the type of helicopter being operated.
<input type="checkbox"/>	<input type="checkbox"/>	Submit valid rigger and signalperson certification(s).
Written Lift Plan <i>(developed by Project Managers & Contractors)</i>		
<input type="checkbox"/>	<input type="checkbox"/>	On-site competent person name, company, and contact information.
<input type="checkbox"/>	<input type="checkbox"/>	Detailed scope of work. <i>(Must include date(s), times, duration, vehicles/equipment, all parties involved, procedures, lift sequence, and necessary shutdowns.)</i>
<input type="checkbox"/>	<input type="checkbox"/>	Method(s) of communication between all parties during helicopter operations. <i>(E.g., radios, hand signals.)</i>
<input type="checkbox"/>	<input type="checkbox"/>	Description of load(s) to be lifted, rigging equipment, and rigging methods. <i>(E.g., load weights, dimensions, quantity; rigging shackles, slings, spreaders; choker, basket, tag lines.)</i>
<input type="checkbox"/>	<input type="checkbox"/>	Rigging equipment certified, inspected, in good condition, and rated for the loads being lifted. <i>(Certifications must be available upon request.)</i>
<input type="checkbox"/>	<input type="checkbox"/>	Safety measures and emergency procedures that all parties will adhere to during helicopter operations. <i>(Must include no smoking within 100 feet of helicopter, keeping clear of loads and tail rotor, avoiding fall hazards and pinch points, equipment inspections, emergency landing, and PPE.)</i>
<input type="checkbox"/>	<input type="checkbox"/>	Hazard control plan. <i>(E.g., dust, flying debris from rotor wash.)</i>

(Continued)

Written Lift Plan *(developed by Project Managers & Contractors)*

(Continued)

Yes	No	
<input type="checkbox"/>	<input type="checkbox"/>	Refueling plan. (Include fire protection.)
<input type="checkbox"/>	<input type="checkbox"/>	If workers will be within 15 feet of fall hazards greater than 4 feet in height, develop a fall protection plan.
<input type="checkbox"/>	<input type="checkbox"/>	Create detailed helicopter operations, weather shutdown parameters, maximum wind speeds (mph), lightning proximity (miles), rain, snow, ice, etc.
<input type="checkbox"/>	<input type="checkbox"/>	Provide a detailed lift plan drawing indicating the following criteria: <ul style="list-style-type: none"> • Flight path and equipment positions in relation to nearby structures, streets, walkways, and hazards. • Helicopter long line installation and removal areas. • Staging, hoisting, and equipment landing zones. • Helicopter emergency landing zones (ELZs). • Roadway and walkway shutdown locations. • Barricade and flagger positions for vehicle and pedestrian safety and control. • Identification of overhead or flight path hazards.

APPENDIX G:

Conveyor Belt Self-Inspection Checklist

General		
Yes	No	
<input type="checkbox"/>	<input type="checkbox"/>	Do you have an active safety and health program in operation that deals with general safety and health program elements as well as management of hazards specific to your worksite?
<input type="checkbox"/>	<input type="checkbox"/>	Keep a record of inspections, maintenance activities, and repairs performed on the conveyor system.
<input type="checkbox"/>	<input type="checkbox"/>	Is one person clearly responsible for the overall activities of the safety and health program?
<input type="checkbox"/>	<input type="checkbox"/>	Schedule regular maintenance tasks based on the manufacturer's recommendations.
<input type="checkbox"/>	<input type="checkbox"/>	Test the emergency stop system to ensure it is working correctly.
<input type="checkbox"/>	<input type="checkbox"/>	Ensure that emergency stop buttons or pull cords are easily accessible and not obstructed.
Personal Protective Equipment		
<input type="checkbox"/>	<input type="checkbox"/>	Are employers assessing the workplace to determine if hazards that require the use of personal protective equipment (e.g., head, eye, face, hand, or foot protection) are present or are likely to be present?
<input type="checkbox"/>	<input type="checkbox"/>	If hazards or the likelihood of hazards are found, are employers selecting and having affected employees use properly fitted personal protective equipment suitable for protection from these hazards?
<input type="checkbox"/>	<input type="checkbox"/>	Has the employee been trained on PPE procedures, that is, what PPE is necessary for a job task, when they need it, and how to properly adjust it?
<input type="checkbox"/>	<input type="checkbox"/>	Is all protective equipment maintained in a sanitary condition and ready for use?
Visual Inspections		
<input type="checkbox"/>	<input type="checkbox"/>	Are there any signs of damage, such as cuts, fraying, or wear.
<input type="checkbox"/>	<input type="checkbox"/>	Is there debris, spillage, or material buildup on the belt or around the conveyor.

(Continued)

Visual Inspections

(Continued)

Yes	No	
<input type="checkbox"/>	<input type="checkbox"/>	Visually inspect the belt alignment to ensure it is properly centered and tracking correctly.
<input type="checkbox"/>	<input type="checkbox"/>	Verify that all guards and safety devices are in place and functioning correctly.
Belt Tension		
<input type="checkbox"/>	<input type="checkbox"/>	Run the conveyor belt and observe it's movement
<input type="checkbox"/>	<input type="checkbox"/>	Does the belt have any misalignment or is there wandering of the belt.
<input type="checkbox"/>	<input type="checkbox"/>	Adjust the tracking, if necessary, always follow the manufacturer's guidelines.
Pulleys and Rollers		
<input type="checkbox"/>	<input type="checkbox"/>	Inspect pulleys and rollers for any signs of damage, excessive wear, or misalignment.
<input type="checkbox"/>	<input type="checkbox"/>	Ensure that all pulleys are clean and free from debris.
<input type="checkbox"/>	<input type="checkbox"/>	Does pulleys and rollers have proper amounts of lubricate as per the manufacturer's recommendations.
Belt Splices and Cleanliness		
<input type="checkbox"/>	<input type="checkbox"/>	Inspect the integrity of the splices and ensure they are secure.
<input type="checkbox"/>	<input type="checkbox"/>	Check belt splices for signs of wear, damage, or separation.
<input type="checkbox"/>	<input type="checkbox"/>	Clean the conveyor belt regularly to remove any accumulated dirt, debris, or spillage.
<input type="checkbox"/>	<input type="checkbox"/>	Is there a Safety Data Sheet readily available for each hazardous substance used?
<input type="checkbox"/>	<input type="checkbox"/>	Is there an employee training program for hazardous substances?
<input type="checkbox"/>	<input type="checkbox"/>	Use appropriate cleaning methods and materials that are compatible with the belt material
Belt Fasteners and Fastening		
<input type="checkbox"/>	<input type="checkbox"/>	Inspect belt fasteners (if used) to ensure they are properly secured and not damaged.
<input type="checkbox"/>	<input type="checkbox"/>	Ensure that the drive system is properly lubricated.

(Continued)

Point of Operation

Yes	No	
<input type="checkbox"/>	<input type="checkbox"/>	Inspect the point of operation on the conveyor system where the work is performed, such as loading, unloading, or any other specific operations.
<input type="checkbox"/>	<input type="checkbox"/>	Verify that adequate guarding is in place to prevent access to the point of operation and protect personnel from hazards.
<input type="checkbox"/>	<input type="checkbox"/>	Ensure that the guarding is designed to effectively prevent contact with moving parts, pinch points, or any other potential sources of injury.
<input type="checkbox"/>	<input type="checkbox"/>	Check that the guarding is securely fastened and properly aligned to provide complete coverage of the point of operation.
<input type="checkbox"/>	<input type="checkbox"/>	Ensure that the guarding does not create additional hazards, such as sharp edges, exposed bolts, or gaps that could trap materials or body parts.
<input type="checkbox"/>	<input type="checkbox"/>	Inspect the interlock or safety mechanisms associated with the point of operation guarding to ensure they are functioning correctly.

Guard Inspection

<input type="checkbox"/>	<input type="checkbox"/>	Check that all required guards are in place and securely fastened.
<input type="checkbox"/>	<input type="checkbox"/>	Ensure that guards cover all moving parts, such as belts, pulleys, rollers, and drive systems.
<input type="checkbox"/>	<input type="checkbox"/>	Ensure that guards are properly aligned and provide adequate protection to prevent accidental contact with moving parts.
<input type="checkbox"/>	<input type="checkbox"/>	Verify that the guards are compliant with applicable safety standards and regulations.
<input type="checkbox"/>	<input type="checkbox"/>	Check that guards have appropriate access points for maintenance and inspection purposes, with proper locking mechanisms if necessary.
<input type="checkbox"/>	<input type="checkbox"/>	Verify that the guards are of sufficient strength and durability to withstand normal operating conditions.
<input type="checkbox"/>	<input type="checkbox"/>	Inspect guards for any signs of damage, wear, or tampering.